

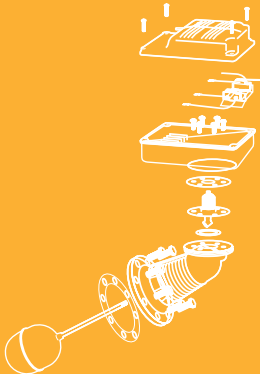

ITT

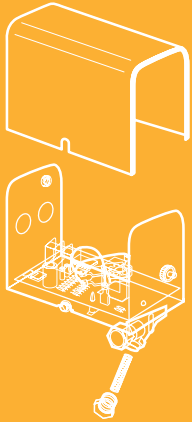

MM-701A

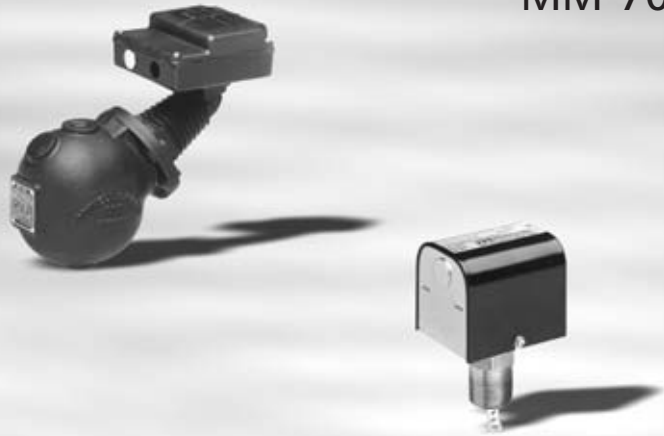

McDonnell & Miller Replacement Parts Catalog



Engineered for life

problem.



Lime build-up on ordinary probe.

no problem.



McDonnell & Miller self-cleaning probe eliminates lime build-up.

Say goodbye to probe maintenance for the next five years with the only low water cut-off with a self-cleaning probe.



*Patent Pending

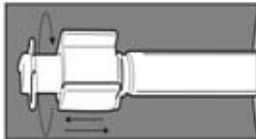

The movement of water around the probe causes the cleaning element to oscillate, constantly removing lime build-up.

McDonnell & Miller's low water cut-offs with our exclusive self-cleaning probe* can save you time and money since probe maintenance is needed only once every five years. The self-cleaning design prevents excessive lime build-up on the probe surface, which can lead to nuisance boiler shutdowns and the potential for water overflow.

McDonnell & Miller offers a wide range of electronic low water cut-offs and other products for hot water and steam boilers and systems.

To learn more visit www.mcdonnellmiller.com



McDonnell Miller



ITT

Engineered for life

The "ITT Engineered Blocks Symbol"; and "Engineered for life" are registered trademarks of ITT Corporation. © 2007





ITT McDonnell & Miller – the industry leader. Delivering reliable performance and safety in boiler and level control products for over 75 years.

Whether it's ease of serviceability, continuous improvement, product enhancements or interchangeability, ITT McDonnell & Miller is continually doing more to give you the best performing residential, commercial and industrial liquid level and flow control products found anywhere.

ITT McDONNELL & MILLER IS AN INTERNATIONALLY CERTIFIED ISO 9001 ORGANIZATION



BOILER CONTROLS FLOW SWITCHES LIQUID LEVEL CONTROLS

ITT McDonnell & Miller is the recipient of the highly coveted ISO 9001 Certification. Recognized by more than 140 countries, these worldwide standards provide a uniform measure of quality procedures in manufacturing and service organizations.

Participation in the rigid and demanding ISO 9000 Certification process is one of our most important activities. We want our customers and competitors – both in the United States and abroad – to know that we are dedicated to designing, producing and marketing the very highest quality products available anywhere.

HOW TO USE THIS CATALOG

This guide will assist you in your tour of the McDonnell & Miller Replacement Parts Catalog. The information contained in the catalog is organized into 4 key categories:

- Products
- Warranty & Return Policy
- Index
- Maintenance & Replacement Interval Guidelines

Easy to identify symbols and product icons will help you specify and select the replacement parts that meet your requirements.

PRODUCTS...

...the complete McDonnell & Miller product line, divided into 3 primary groups:

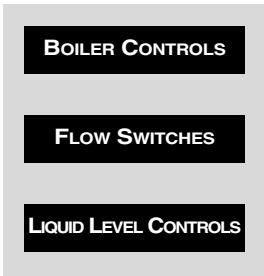

Just check the **CONTENTS** pages for the associated product icons to quickly find the control you need replacement parts for.

WARRANTY & RETURN POLICY...

...gives you all the information regarding McDonnell & Miller warranty and return policies.



INDEX...

...helps you find the information by part number or catalog number.



MAINTENANCE & REPLACEMENT INTERVAL GUIDELINES...

...the easy to read guides will help keep you on track with suggested product maintenance and replacement intervals.

Recommended Replacement Intervals

Product	Series	Recommended Maintenance	Recommended Replacement Interval (Maximum)
Low Water Cut-Offs	150, 157, 158, 159, 150S, 157, 158S, 159S	Blow down and test daily inspect annually.	15 years
	69, 168, 205, 369, 469	Inspect and test annually.	10 years
	67, 767	Blow down weekly, inspect and test annually.	10 years
	61, 63, 64, 764	Blow down weekly, inspect and test annually.	10 years
	42	Blow down daily, inspect and test annually.	10 years















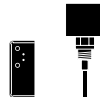
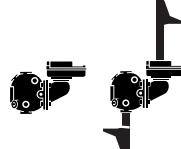
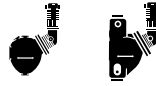

Replacement Parts for:

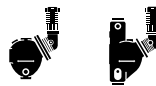
Boiler Controls5
Liquid Level Controls49
Flow Switches53





















General Information

Part Number Cross Reference66
Index68
Warranty & Return Policy72
Maintenance & Replacement Interval Guidelines73





BOILER CONTROL REPLACEMENT PARTS

LOW WATER CUT-OFFS	FOR SERIES	PAGE	LOW WATER CUT-OFFS	FOR SERIES	PAGE
<ul style="list-style-type: none"> • For Hot Water Boilers 			<ul style="list-style-type: none"> • For Steam Boilers 		
Replacement Probes			PS-800 Series		5
	PS-850 Series		750 Series		6
	RB Series		<ul style="list-style-type: none"> • Combination Low Water Cut-Off/ Pump Controllers for Steam Boilers 		
	750 Series		42/42A and 42S/42S-A		18
<ul style="list-style-type: none"> • For Steam Boilers 			93/193		20
	61		94/194		22
	63		150/157 150S/157S		24
	64		And		
	764		150E/157E		
	67				
	767				
	69				

















BOILER CONTROL REPLACEMENT PARTS (continued)

<u>WATER FEEDERS</u>	<u>FOR SERIES</u>	<u>PAGE</u>	<u>WATER FEEDERS</u>	<u>FOR SERIES</u>	<u>PAGE</u>
• <i>Electric</i>	Uni-Match® WF2	 29	• <i>Make-Up</i>	21	 31
	101-A	 30		25-A	 32
• <i>Mechanical</i>	47/47-2	  38	221	 33	
	247/247-2	  40	551-S	 34	
	51/51-2	  42	847	 35	
	51-S/51-S-2	  44	851	 36	
	53/53-2	  46	851-S	 37	
<u>VALVES</u>					
			• <i>Test-N-Check®</i>	TC-4	 48

LIQUID LEVEL CONTROL PRODUCTS

REMOTE SENSORS	FOR SERIES	PAGE	FLOAT ACTUATED	FOR SERIES	PAGE
	RS	 49		27-W	 51
<u>PNEUMATIC ACTUATED</u>				3155	 52
	PFC/VFS	 50			

FLOW SWITCH PRODUCTS

LIQUID FLOW	FOR SERIES	PAGE	LIQUID FLOW	FOR SERIES	PAGE
<i>• General Purpose</i>	FS4-3	 53	<i>• Industrial</i>	FS7-4	 60
	FS4-3-T	 54		FS7-4E	 61
	FS5	 55		FS7-4W	 61
	FS8-W	 56			
	FS251	 57	<u>AIR FLOW</u>	AF1	 62
	FS254	 57		AFE-1	 63
<i>• High Sensitivity</i>	FS1	 58		AF2	 64
	FS1-W	 58		AF3	 65
	FS6	 59			
	FS6-W	 59			



Replacement Probes

PA-800

For Model	Repl. Probe Model No.	Part Number	Description	Weight lbs. (kg)
PS-801-120	PA-800	354081	Probe	0.5 (.23)
PS-851-120				
PS-802-24				
PS-852-24				
RS-1-LP				
PS-851-M-120				
PS-852-M-24				
PS-801-M-120				
PS-802-M-24				
750P-MT-120				

Dimensions, in. (mm)

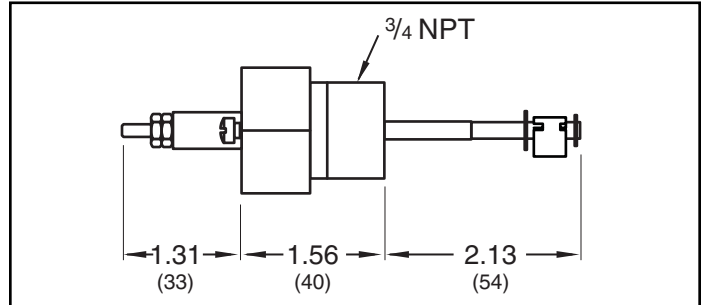

PA-800-U

For Model	Repl. Probe Model No.	Part Number	Description	Weight lbs. (kg)
PS-801-U-120	PA-800-U	354141	Probe	0.5 (.23)
PS-802-U-24				
PS-851-M-U-120				
PS-851-U-120				
PS-802-M-U-24				
PS-801-M-U-120				
750P-MT-U-120				

Dimensions, in. (mm)

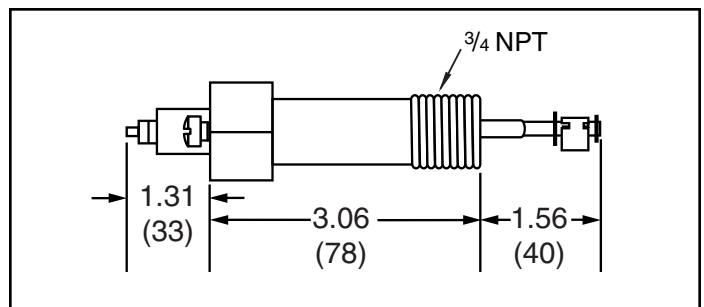



Replacement Probes

PA-800-RX2

For Model	Repl. Probe Model No.	Part Number	Description	Weight lbs. (kg)
PS-801-RX2-24	PA-800-RX2	354140	Probe	0.5 (.23)
PS-802-RX2-24				
PS-851-RX2-120				

Dimensions, in. (mm)

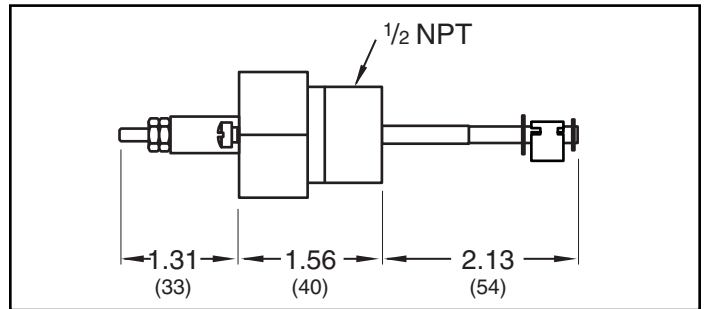

PA-RB-122

For Model	Repl. Probe Model No.	Part Number	Description	Weight lbs. (kg)
RB-122	PA-RB-122	354083	Probe	0.5 (.23)
RS-1-LP-S				
PS-851-SP-120				
PS-852-SP-24				
RB-120				
PS-851-M-SP-120				
PS-852-M-SP-24				

Dimensions, in. (mm)

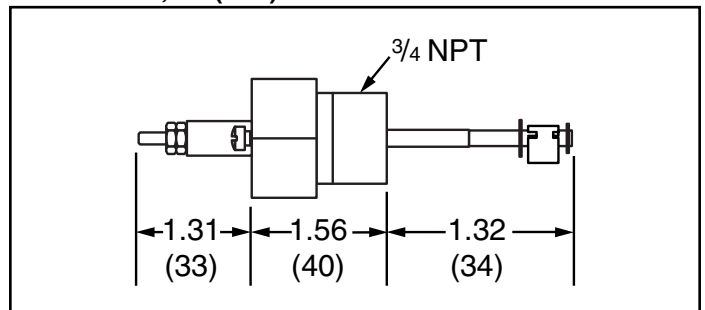



Low Water Cut-Offs – Float Type For Steam Boilers

Series 61

Low Water Cut-Offs



Replacement Head Mechanisms

For Series	Repl. Head Model No.	Part Number	Description	Weight lbs. (kg)
61	61-HD or	140300	Head mechanism	3.5 (1.6)
	6667	153825	Head mechanism	1.5 (0.7)

Head mechanisms include a gasket and bolts.

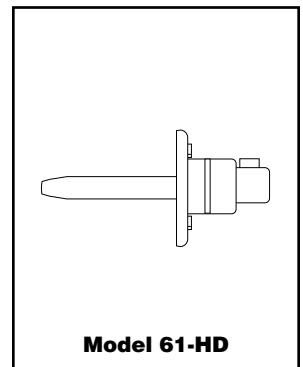

Components

Key	Part Number	Catalog Number	Description	Weight lbs. (kg)
1	302600	CO-12	Head Gasket	0.1 (0.5)
2	318800	67-12	Gasket	0.1 (0.5)
3	344200	SA67-2	Float & Bellows Assembly	0.3 (.14)
4	309100	11	Switch	0.5 (.23)
5	309151	11-M	Switch w/Manual Reset	0.5 (.23)
6	309200	11-MV	Switch for Millivolt Service	0.5 (.23)

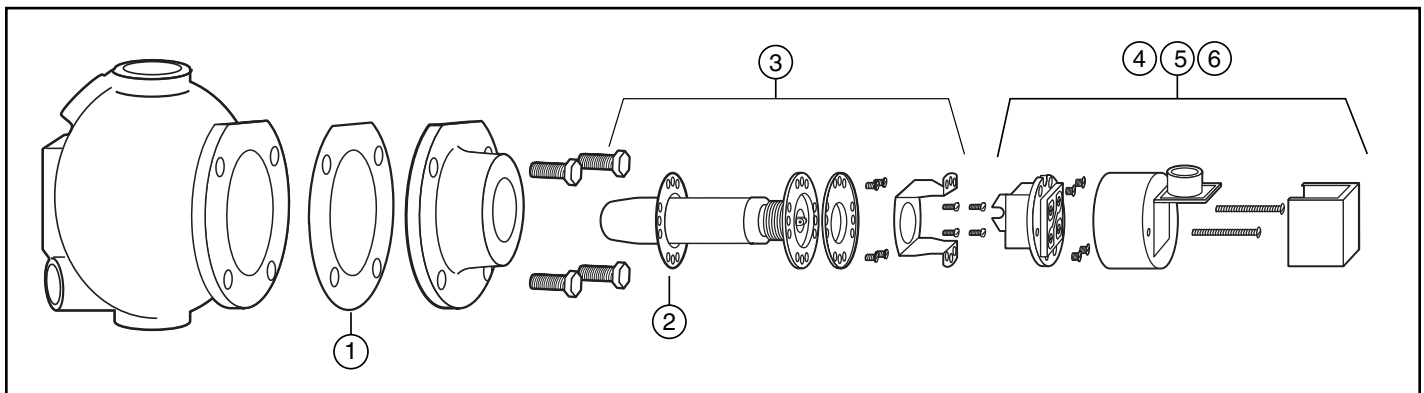
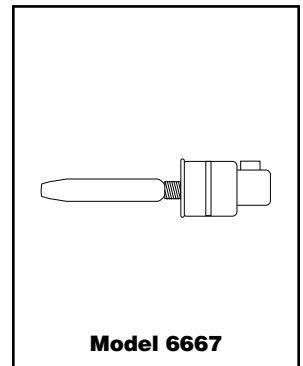



Low Water Cut-Offs – Float Type For Hot Water Boilers

Series 63

Low Water Cut-Offs



Series 63

Replacement Head Mechanisms

For Model	Repl. Head Model No.	Part Number	Description	Weight lbs. (kg)
63	63-HD	142600	Head mechanism w/ No. 2 switch	7.0 (3.2)
63-B				
63-BM	63-M-HD	143200	63-HD w/manual reset	7.0 (3.2)
63-M				

Head mechanisms include a gasket and bolts.

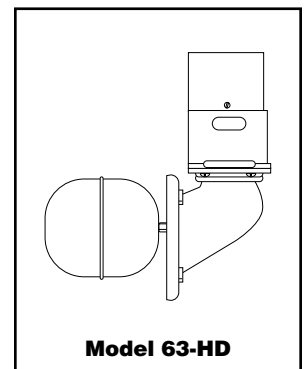

Model 63-HD

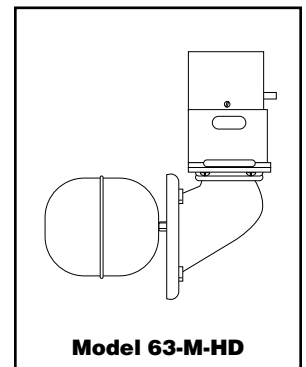

Model 63-M-HD

Components (shown on page 9)

Item Number	Part Number	Model Number	Description	Weight lbs. (kg)
1	110000	2	Switch	1.0 (0.5)
2	110100	2-M	Switch w/manual reset	1.0 (0.5)
3	343200	SA63-5	Bellows assembly	1.5 (7.3)
4	302500	CO-11	Gasket	0.1 (.05)
5	343400	SA63-30	Float	1.0 (0.5)
6	302600	CO-12	Head gasket	0.1 (.05)
7	302900	CO-106	Cam	0.1 (.05)



Low Water Cut-Offs – Float Type For Hot Water Boilers

Series 63 (continued)

Low Water Cut-Offs

Components

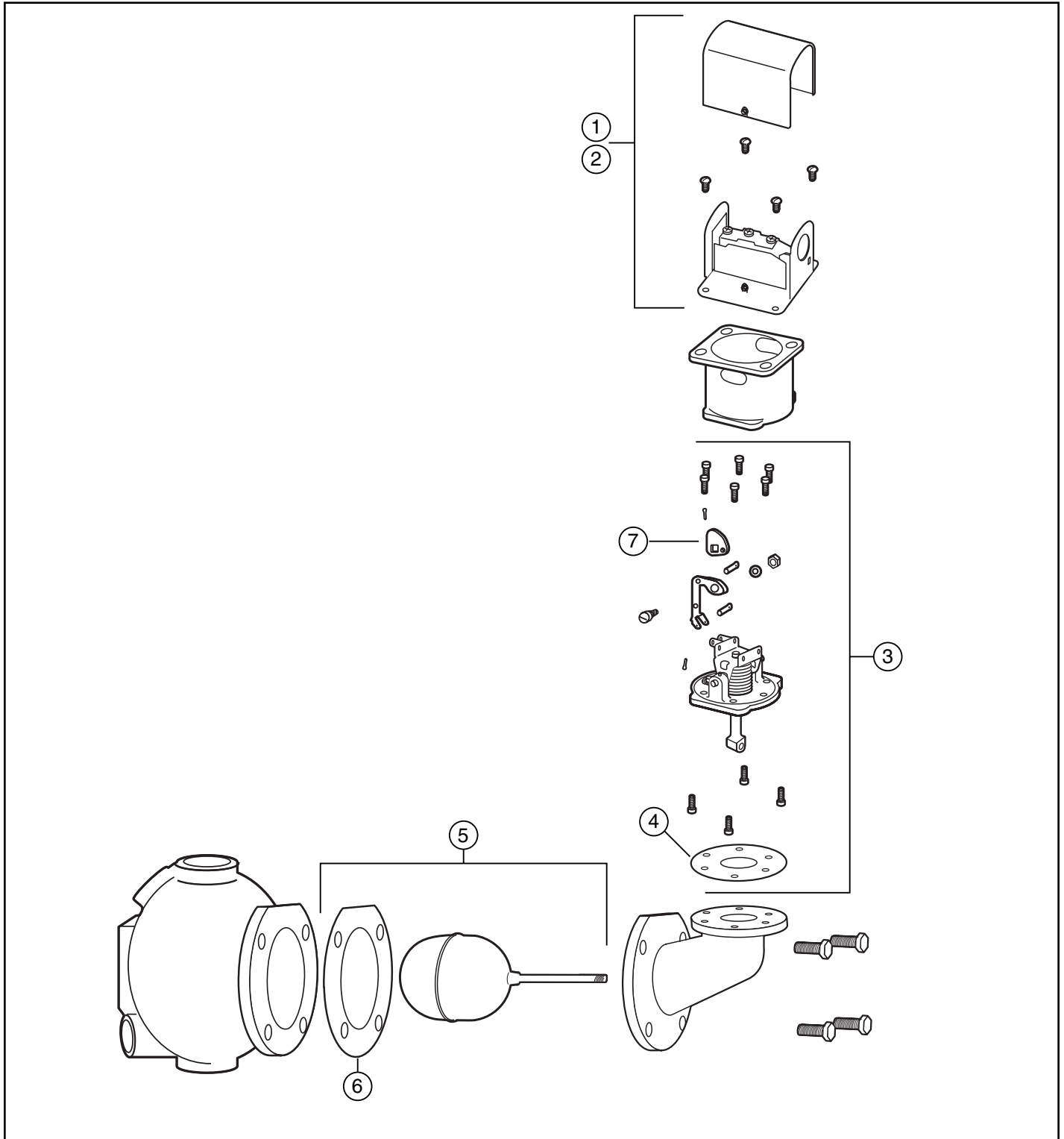



BOILER CONTROLS

Low Water Cut-Offs – Float Type For Hot Water Boilers

Series 64

Low Water Cut-Offs



Series 64



Model 64-A

Replacement Head Mechanisms

For Series	Repl. Head Model No.	Part Number	Description	Weight lbs. (kg)
64	64-HD	144400	Head mechanism	4.0 (1.8)
64-A				

Head mechanisms include a gasket and bolts.

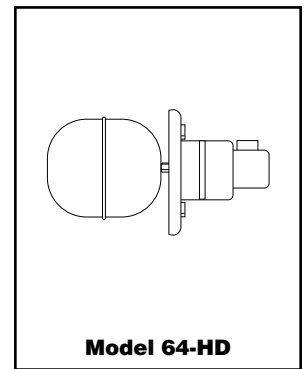

Model 64-HD

Components (shown on page 11)

Item Number	Part Number	Model Number	Description	Weight lbs. (kg)
1	343600	SA64-30	Float assembly	1.0 (0.5)
2	302600	CO-12	Head gasket	0.1 (.05)
3	343500	SA64-2	Bellows assembly (includes item 2)	0.3 (.14)
4	318800	67-12	Gasket	0.1 (.05)
5	309100	11	Switch	0.5 (.23)
6	309151	11-M	No. 11 w/manual reset	0.5 (.23)
7	309200	11-MV	No. 11 for Millivolt service	0.5 (.23)
8*	332800	MA-259	Quick hook-up fittings (includes item 8, 9, 10)	4.5 (2.0)
9*	351800	SA259-24	Upper quick hook-up	1.7 (.77)
10*	349500	SA159-24	Lower quick hook-up	1.7 (.77)
11*	349400	SA159-17	Black "Y" assembly	2.3 (1.0)

*Available for 64-A models only



Low Water Cut-Offs – Float Type For Hot Water Boilers

Series 64 (continued)

Low Water Cut-Offs

Components

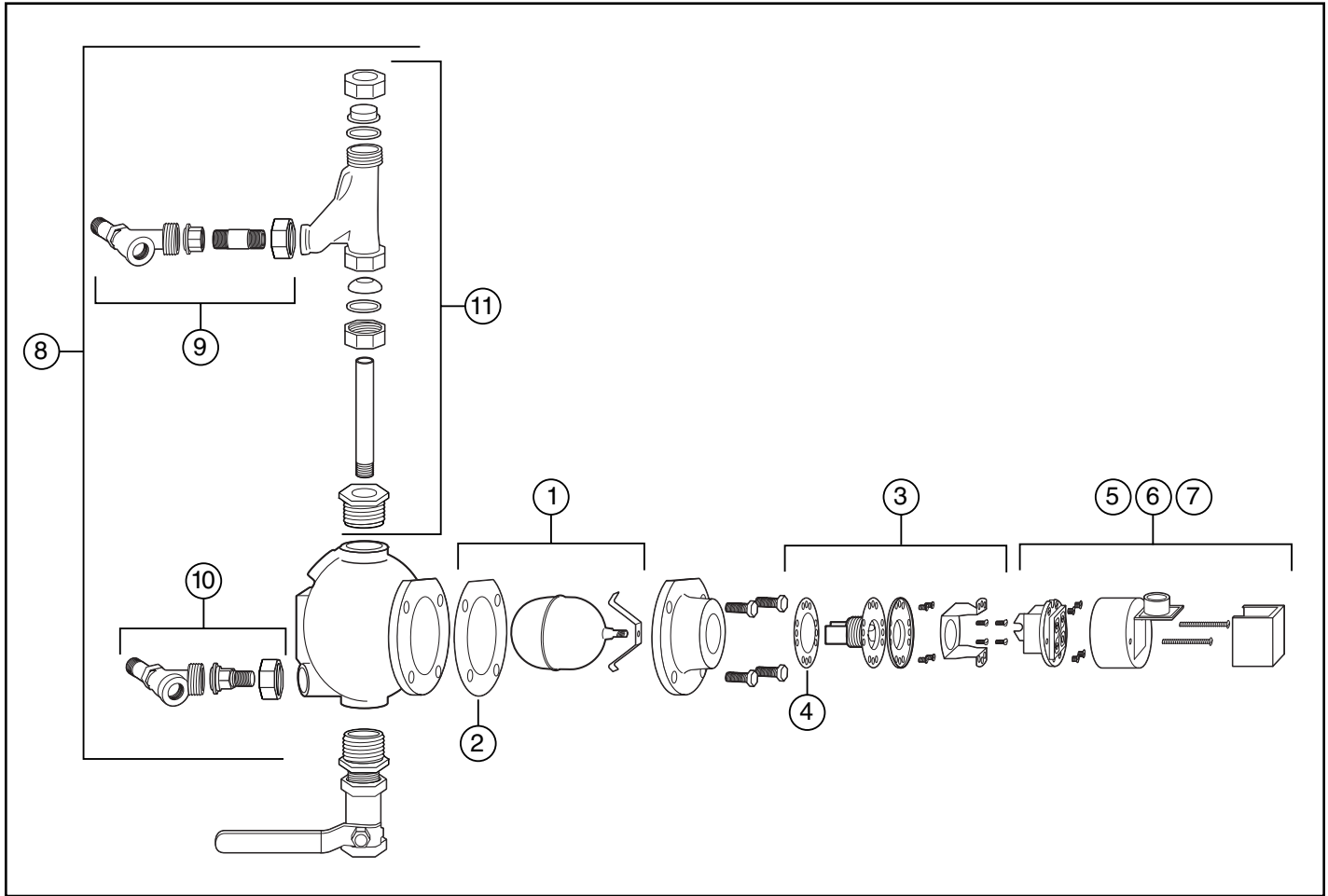



BOILER CONTROLS

Low Water Cut-Offs – Float Type For Hot Water Boilers

Series 764

Low Water Cut-Offs



Series 764

Replacement Head Mechanisms

For Series	Repl. Head Model No.	Part Number	Description	Weight lbs. (kg)
764	64-HD	144400	Head mechanism	4.0 (1.8)

Head mechanisms include a gasket and bolts.

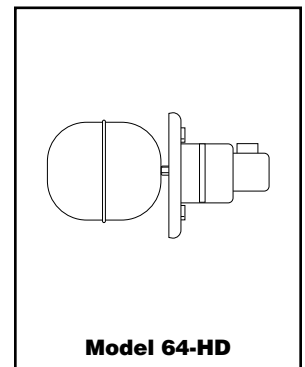

Model 64-HD

Components (shown on page 13)

Item Number	Part Number	Model Number	Description	Weight lbs. (kg)
1	343600	SA64-30	Float assembly	1.0 (0.5)
2	302600	CO-12	Head gasket	0.1 (.05)
3	343500	SA64-2	Bellows assembly (includes item 2)	0.3 (.14)
4	318800	67-12	Gasket	0.1 (.05)
5	309100	11	Switch	0.5 (.23)
6	309151	11-M	No. 11 w/manual reset	0.5 (.23)
7	309200	11-MV	No. 11 for Millivolt service	0.5 (.23)



Low Water Cut-Offs – Float Type For Hot Water Boilers

Series 764 (continued)

Low Water Cut-Offs

Components

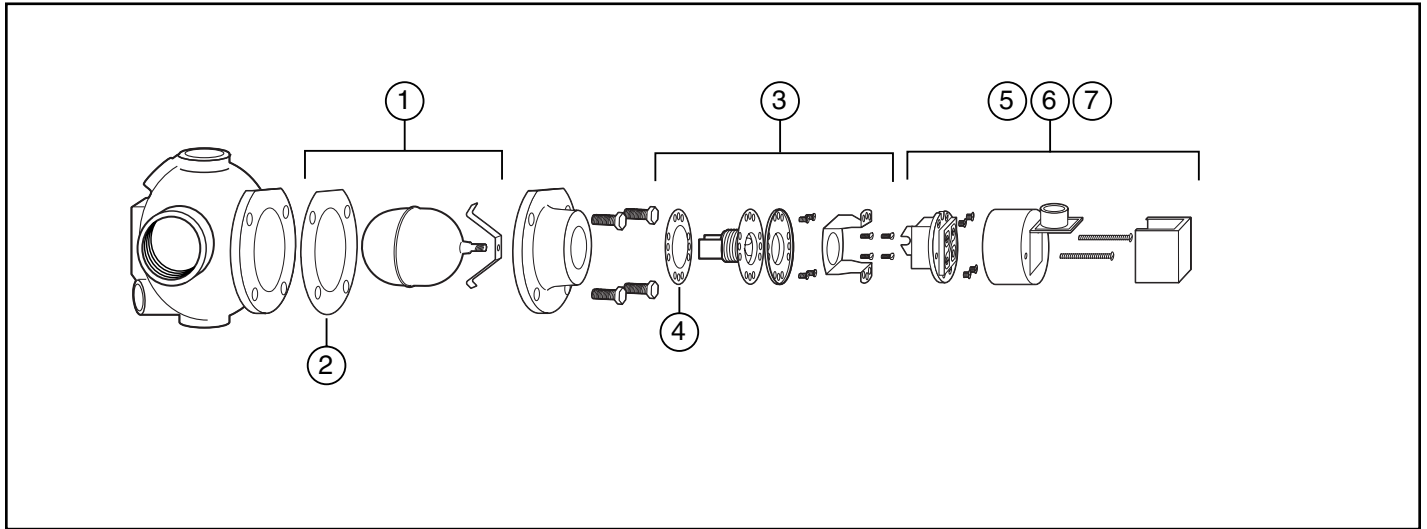



BOILER CONTROLS

Low Water Cut-Offs – Float Type For Steam Boilers

Series 67 Low Water Cut-Offs



Replacement Head Mechanisms

For Model	Repl. Head Model No.	Part Number	Description	Weight lbs. (kg)
67				
67-LQHU	6667	153825	Head mechanism	1.5 (0.7)
67-G	6667MV	153850	6667 for Millivolt service	1.5 (0.7)

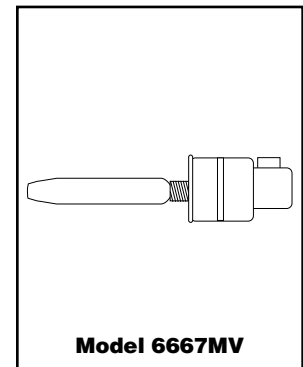
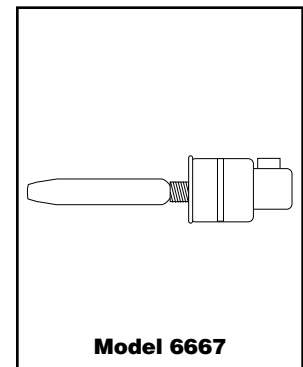

Components (shown on page 15)

Item Number	Part Number	Model Number	Description	Weight lbs. (kg)
1	344100	SA66-35	Upper tube assembly	1.0 (0.5)
2	334600	MA559	Quick hook-up fittings	2.5 (1.1)
3	318800	67-12	Gasket	0.1 (.05)
4	344200	SA67-2	Float and bellows assembly	1.0 (0.5)
5	309100	11	Switch	0.5 (.23)
6	309151	11-M	Switch w/manual reset	0.5 (.23)
7	309200	11-MV	No. 11 for Millivolt service	0.5 (.23)
8	310447	14-B	Blow-down valve	0.5 (.23)
9	313200	37-39	Blow-down valve gasket	0.1 (.05)



Low Water Cut-Offs – Float Type For Steam Boilers

Series 67 (continued)

Low Water Cut-Offs

Components

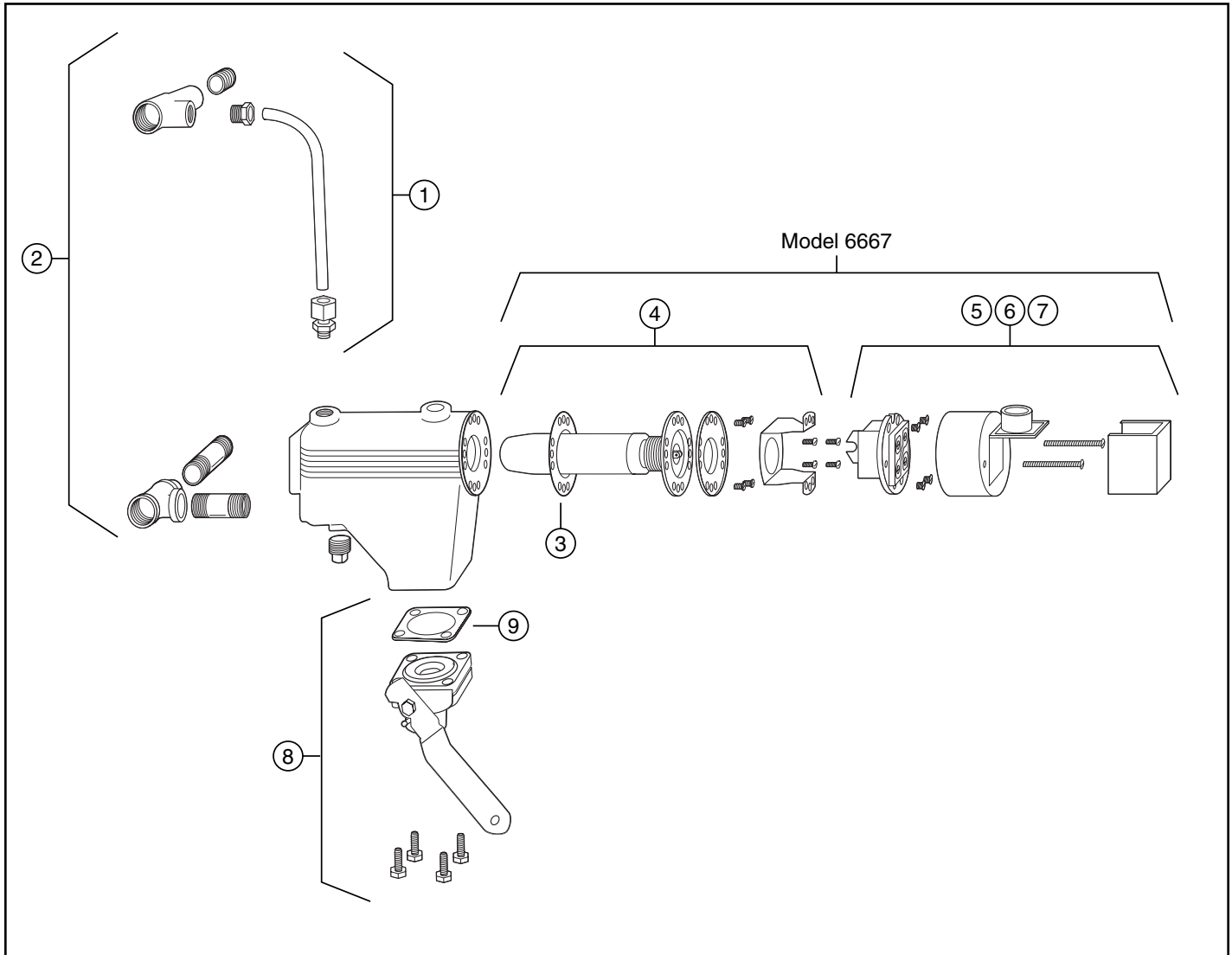



BOILER CONTROLS

Low Water Cut-Offs – Float Type For Steam Boilers

Series 767

Low Water Cut-Offs

Replacement Head Mechanisms

For Model	Repl. Head Model No.	Part Number	Description	Weight lbs. (kg)
767	6667	153825	Head mechanism	1.5 (0.7)



Series 767

Components

Item Number	Part Number	Model Number	Description	Weight lbs. (kg)
1	318800	67-12	Gasket	0.1 (.05)
2	344200	SA67-2	Float and bellows assembly	1.0 (0.5)
3	309100	11	Switch	0.5 (.23)
4	309151	11-M	Switch w/manual reset	0.5 (.23)
5	309200	11-MV	No. 11 w/Millivolt service	0.5 (.23)
6	310447	14-B	Blow-down valve	0.5 (.23)
7	313200	37-39	Blow-down valve gasket	0.1 (.05)

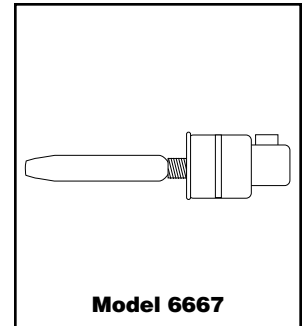

Model 6667

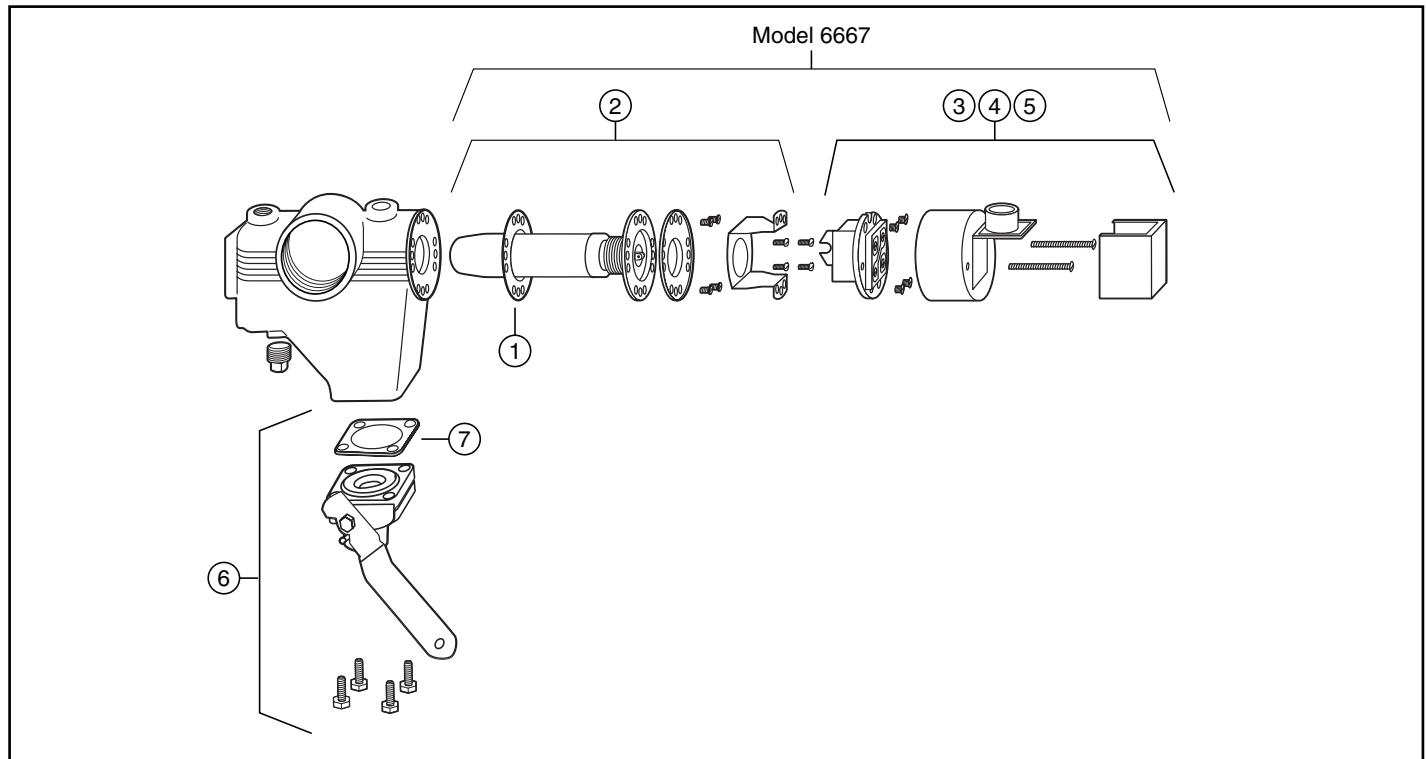



Low Water Cut-Offs – Float Type For Steam Boilers

Series 69

Low Water Cut-Offs

Replacement Head Mechanisms

For Model	Repl. Head Model No.	Part Number	Description	Weight lbs. (kg)
69				
69-J				
169				
269	6667	153825	Head mechanism	1.5 (0.7)
369				
469				
569				
69-MV-P	6667-MV	153850	6667 w/Millivolt service	1.5 (0.7)
369-MV				

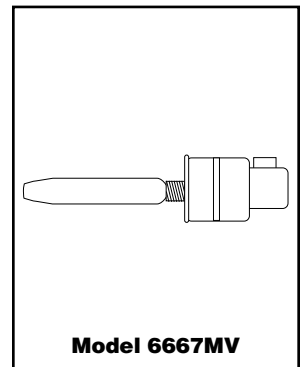
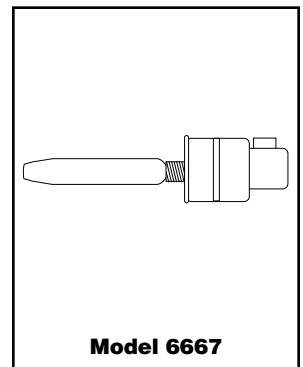

Components

Item Number	Part Number	Model Number	Description	Weight lbs. (kg)
1	344300	SA69-104	Shield assembly	0.5 (.23)
2	320500	69-112	Gasket	0.1 (.05)
3	318826	69-113	O-ring	.01 (.004)
4	318827	69-114	O-ring	.01 (.004)
5	318800	67-12	Gasket	0.1 (.05)
6	309100	11	Switch	0.5 (.23)
7	309151	11-M	Switch w/Manual Reset	0.5 (.23)
8	309200	11-MV	Switch for Millivolt Service	0.5 (.23)
9	344200	SA67-2	Float & Bellows Assembly	0.1 (.05)

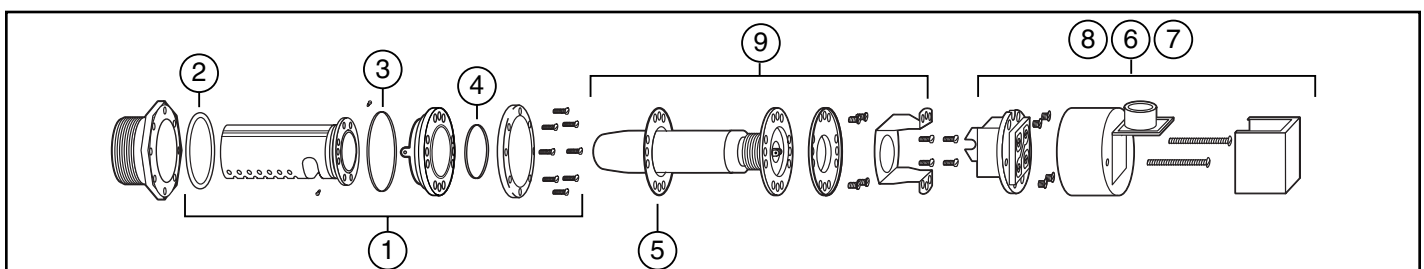



Combination Low Water Cut-Off/Pump Controllers For Steam Boilers

Series 42 and 42S Low Water Cut-Off/Pump Controllers



Replacement Head Mechanisms

For Model	Repl. Head Model No.	Part Number	Description	Weight lbs. (kg)
42S	42S-HD	129502	Head mechanism	7.5 (3.4)

Head mechanisms include a gasket and bolts.

Components (shown on page 19)

Item Number	Part Number	Model Number	Description	Weight lbs. (kg)
1	302600	CO-12	Head gasket	0.1 (.05)
2*	328300	MA-159	Quick hook-up fittings (includes items 4, 5, 6)	6.0 (2.7)
3*	351800	SA259-24	Upper quick hook-up fittings	1.7 (.77)
4*	349500	SA159-24	Lower quick hook-up fittings	1.7 (.77)
5*	349400	SA159-17	Black "Y" assembly	3.0 (1.4)
6	347900	SA150-106R	Bellows Assembly	0.4 (.18)

* Available for 42S-A models only.

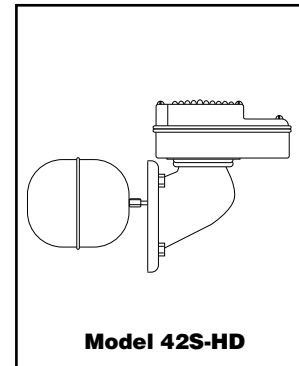

Replacement Switch Information

IMPORTANT:

- Snap switches must be replaced as an assembly.
- We recommend complete head replacement to eliminate the need for field replacement of the switch assembly.
- Series 42 & 42S Replacement Switch Assemblies are not interchangeable and must be selected and ordered for the specific control model(s) on which they will be installed.

Replacement Switch Assemblies For Series 42S

For Model	Repl. Switch Model No.	Part Number	Description	Weight lbs. (kg)
42S	SWA-42S	310488	Snap-action switch assembly	0.5 (.23)

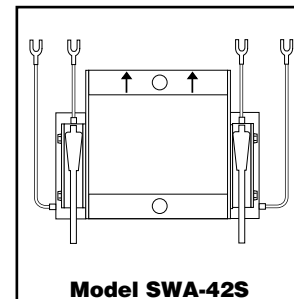



Combination Low Water Cut-Off/Pump Controllers For Steam Boilers

Series 42 and 42S (continued)

Low Water Cut-Off/Pump Controllers

Components

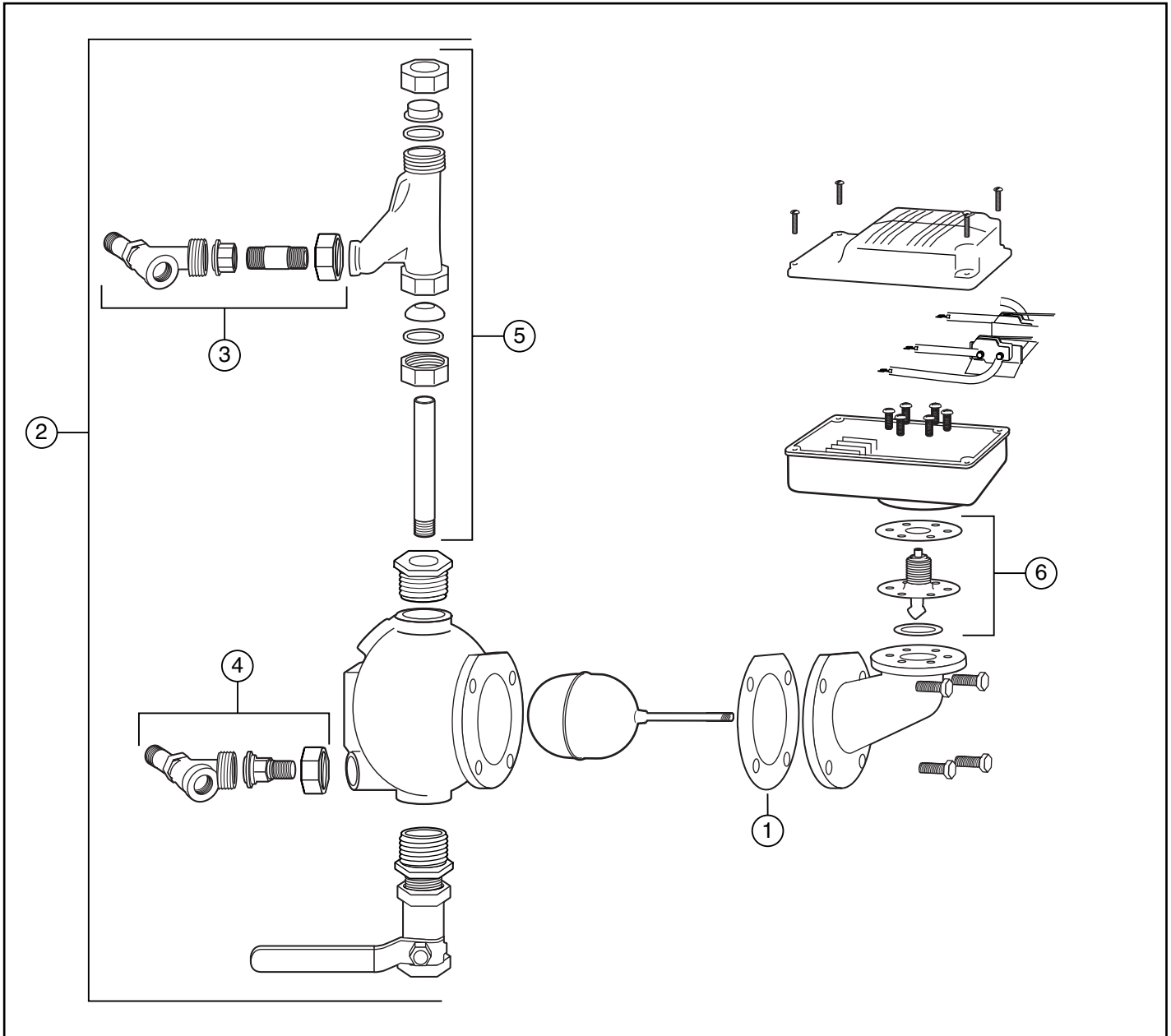



BOILER CONTROLS

Combination Low Water Cut-Off/Pump Controllers For Steam Boilers

Series 93 & 193

Low Water Cut-Off/Pump Controllers

Replacement Head Mechanisms

For Model	Part Number	Repl. Head Model No.	Description	Weight lbs. (kg)
93, 193	162400	93-HD	Head mechanism	16 (7.25)
	163200	93-7B-HD	Head mechanism with 7B switch	16 (7.25)
	162600	93-M-HD	Head mechanism, manual reset	16 (7.25)
	163300	93-7B-M-HD	Head mechanism with 7B switch, manual reset	16 (7.25)

Components (shown on page 21)

Item Number	Part Number	Model Number	Description	Weight lbs. (kg)
1	162402	93-HDLS	Head w/o switch	15.0 (6.8)
2	345700	SA91-60	Float (includes item 3)	0.7 (.32)
3	325400	150-14	Gasket	0.1 (.05)
4	110300	5	Electric switch	3.5 (1.6)
5	110400	5-M	No. 5 w/manual reset	3.5 (1.6)
6	110800	7B	Electric switch/ proportioning control	4.0 (1.8)
7	110900	7B-M	No. 7B w/manual reset	4.0 (1.8)

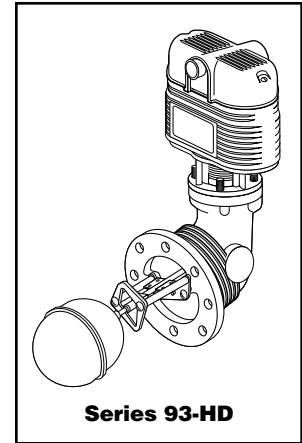

#5 Switch

1	344800	SA91-30B	Burner Switch Contact Assembly <small>(Red dot on terminal panel) (Includes 1A terminal panel)</small>	0.1 (.05)
2	345000	SA91-30P	Pump Switch Contact Assembly <small>(Blue dot on terminal panel) (Includes 2A terminal panel)</small>	0.1 (.05)

#7B Switch

1	344800	SA91-30B	Burner Switch Contact Assembly <small>(Red dot on terminal panel) (Includes 1A terminal panel)</small>	0.1 (.05)
2	309000	7B-1R	Resistor/Slide Wire Assembly	0.1 (.05)
3	345150	SA7-30	Terminal Panel	0.5 (.23)



Combination Low Water Cut-Off/ – Pump Controllers For Steam Boilers

Series 93 & 193 (continued)

Low Water Cut-Off/Pump Controllers

Components

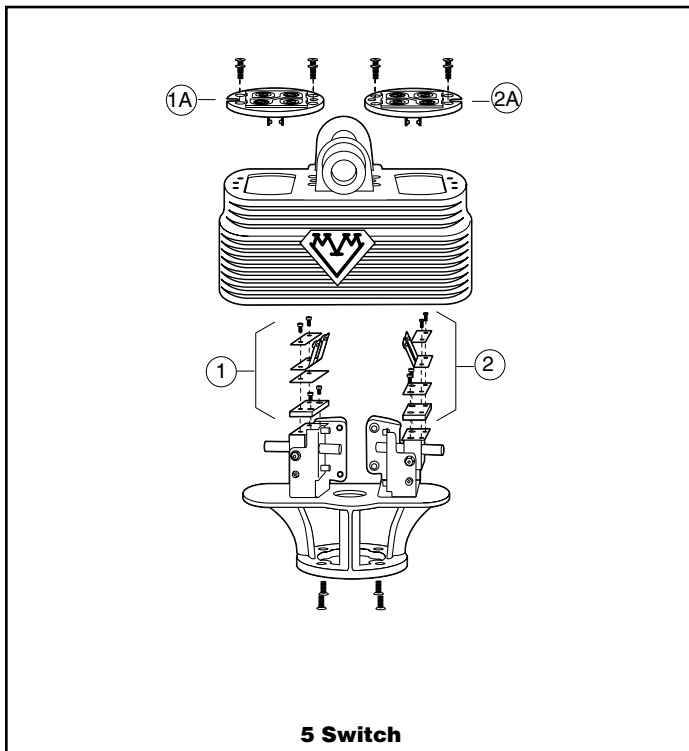
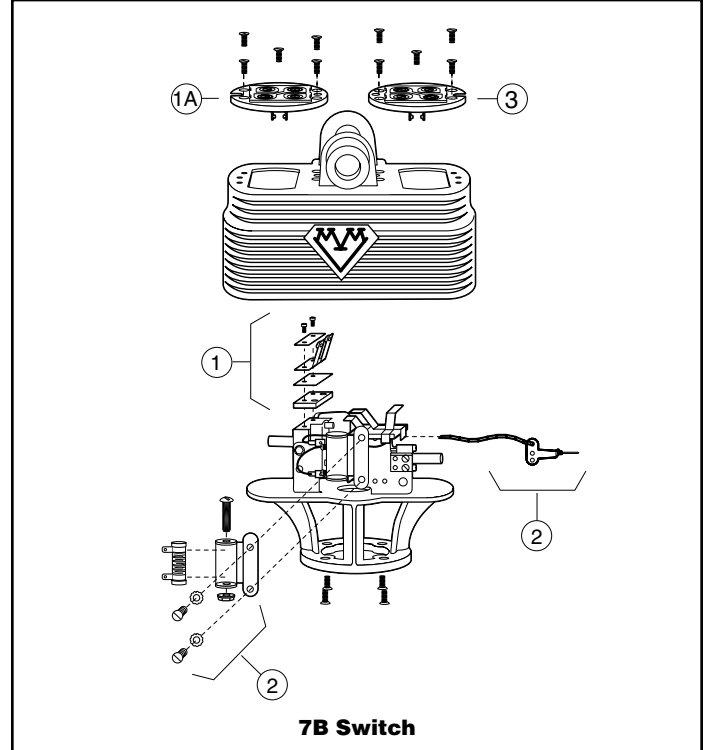
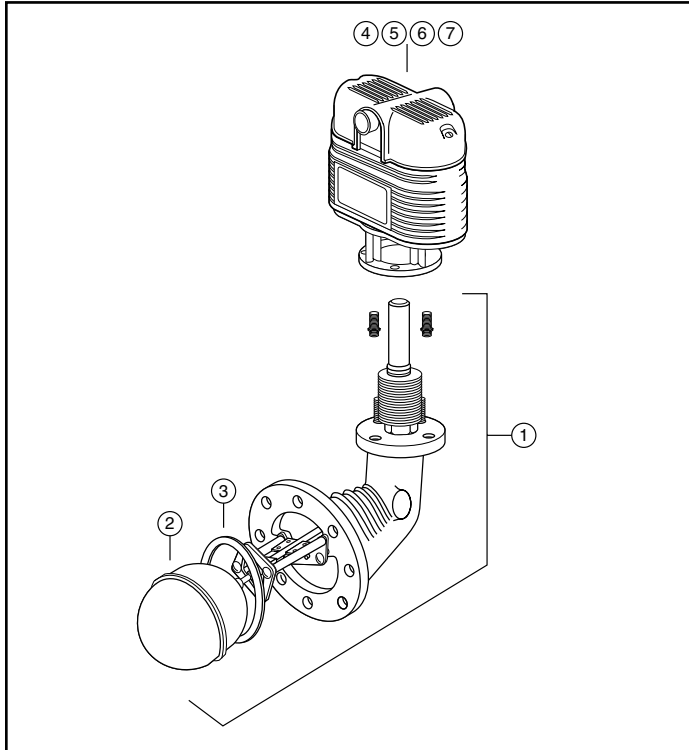

BOILER CONTROLS



BOILER CONTROLS

Combination Low Water Cut-Off/Pump Controllers For Steam Boilers

Series 94 & 194

Low Water Cut-Off/Pump Controllers

Replacement Head Mechanisms

For Model	Part Number	Repl. Head Model No.	Description	Weight lbs. (kg)
94, 194	165300	94-HD	Head mechanism	21 (9.52)
	166000	94-M-HD	Head mechanism, manual reset	21 (9.52)
	166400	94-7B-HD	Head mechanism with 7B switch	21 (9.52)
	166500	94-7B-M-HD	Head mechanism with 7B switch, manual reset	21 (9.52)

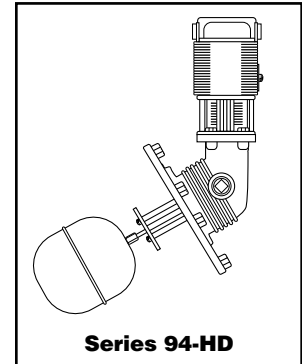

Components (shown on page 23)

Item Number	Part Number	Model Number	Description	Weight lbs. (kg)
1	165302	94-HDLS	Head w/o switch	15.0 (6.8)
2	345700	SA91-60	Float (includes item 3)	0.7 (.32)
3	323300	92-68	Gasket	0.1 (.05)
4	110300	5	Electric switch	3.5 (1.6)
5	110400	5-M	No. 5 w/manual reset	3.5 (1.6)
6	110800	7B	Electric switch/ proportioning control	4.0 (1.8)
7	110900	7B-M	No. 7B w/manual reset	4.0 (1.8)



#5 Switch

1	344800	SA91-30B	Burner Switch Contact Assembly (Red dot on terminal panel) (Includes 1A terminal panel)	0.1 (.05)
2	345000	SA91-30P	Pump Switch Contact Assembly (Blue dot on terminal panel) (Includes 2A terminal panel)	0.1 (.05)



#7B Switch

1	344800	SA91-30B	Burner Switch Contact Assembly (Red dot on terminal panel) (Includes 1A terminal panel)	0.1 (.05)
2	309000	7B-1R	Resistor/Slide Wire Assembly	0.1 (.05)
3	345150	SA7-30	Terminal Panel	0.5 (.23)



Combination Low Water Cut-Off/ – Pump Controllers For Steam Boilers

Series 94 & 194 (continued) Low Water Cut-Off/Pump Controllers

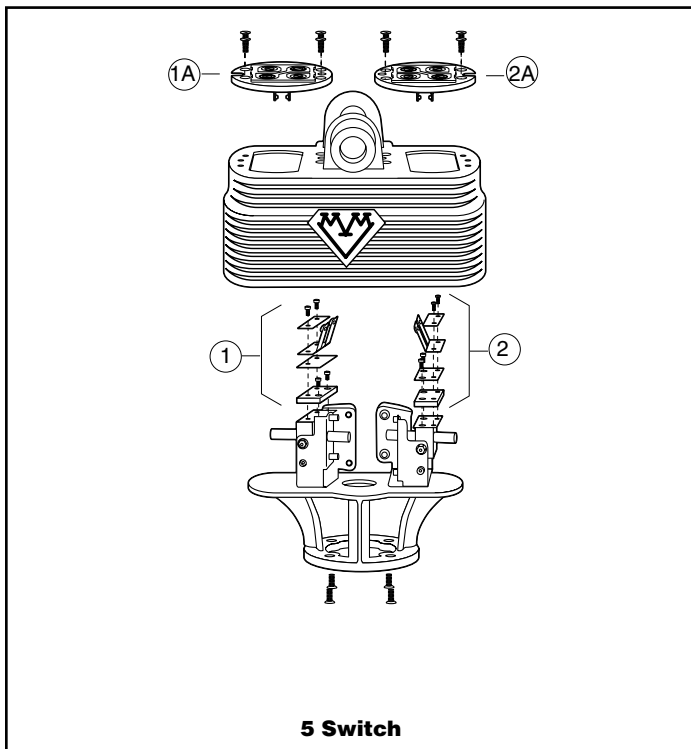
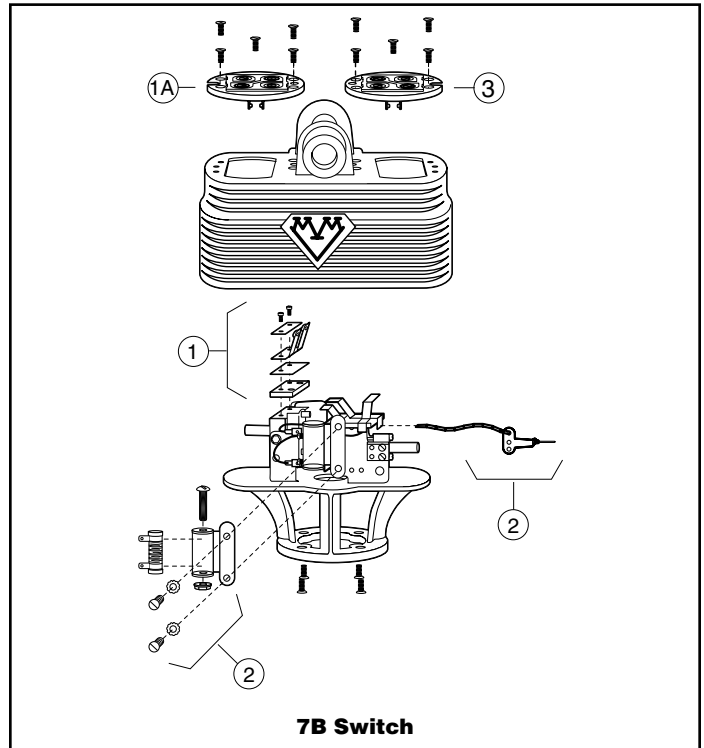
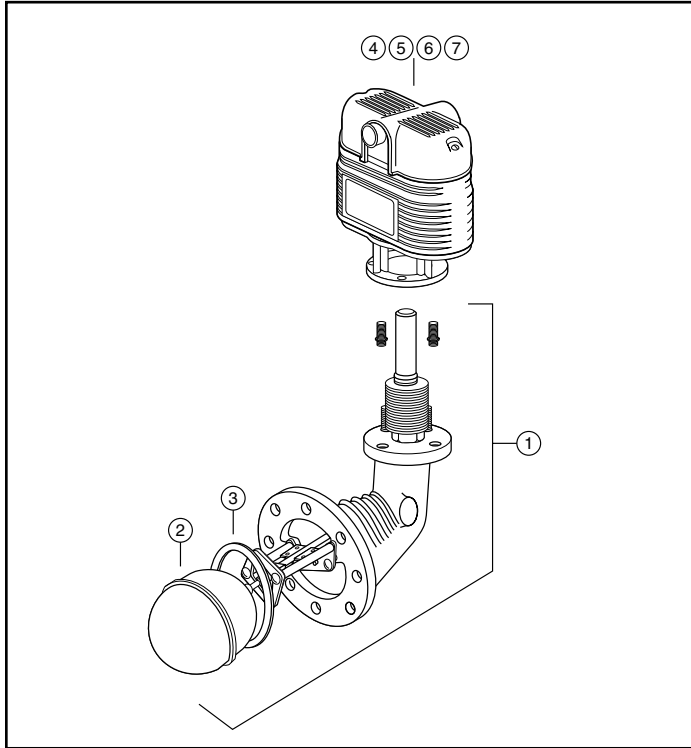



Low Water Cut-Off/Pump Controllers For Steam Boilers

Series 150, 150S & 150E Series 157, 157S & 157E

Two Series of LWCO controls (Series 150S and Series 150E) are available as alternatives for Series 150 LWCO controls that contain mercury switches. Please keep in mind that in a replacement or repair situation you do not have to change out the entire control. A head replacement (i.e. 150E-HD or 150S-HD) is all that's required.

There may be additional letters such as 'B', 'R', 'RL', etc. in the sales catalog designation of the control. These additional letters designate tapping locations and sizes which have no affect on which head mechanism to purchase. All head mechanisms are interchangeable and can be installed on any body.

'MD' Models

The 'MD' model should be used as a replacement head when the boiler operating pressure is less than 50psi. These were created to provide a control with factory settings to compensate for the narrowing of setpoints. The larger differential between pump on and burner off reduces the potential for nuisance burner shutdown.

It is important to understand that regardless of which control is used (Series 150E or 150S), there are requirements that lead to the best performance of ALL level controllers and LWCO's:

- Use of properly-sized pump starters/relays in the pump control circuitry
- Pumps that are balanced to the system requirements
- Equalizing piping, per the boiler manufacturer's recommendations, to properly sense the boiler water level
- Industry accepted blowdown piping to provide best cleaning action of the control chamber, float linkage mechanism and/or probes
- Proper periodic blowdown of the boiler controls.
- Proper chemical treatment of boiler water.
- Annually cleaning and careful examination of the float mechanism, probes, and electrical switches or controls. More frequent cleaning may be required for exceptionally dirty steam systems.





Low Water Cut-Off/Pump Controllers For Steam Boilers

Series 150, 150S & 150E Series 157, 157S & 157E (continued)

Replacement Head Mechanisms

For Model	Part Number	Repl. Head Model No.	Description	Weight lbs. (kg)
150S-HD or 150S-M-HD	173003	150S-HD	Head mechanism	11.0 (5.0)
150S-MD-HD	173203	150S-HD w/manual reset		11.0 (5.0)
150S-M-MD-HD	173103	150S-HD w/maximum differential		11.0 (5.0)
150S-M-MD-HD	173302	150S-HD w/maximum reset and maximum differential		11.0 (5.0)
158S-HD or 158S-M-HD	178602	158-S-HD	Head mechanism	12.5 (5.7)
158S-M-HD	178702	158-S-HD w/manual reset		12.5 (5.7)
159S-HD	178702	158-S-HD	Head mechanism	12.0 (5.7)
150E-HD	171640	150E-HD	Head, automatic reset	7.45 (3.48)
150E-M	171650	150E-HD	Head, manual reset	7.45 (3.48)

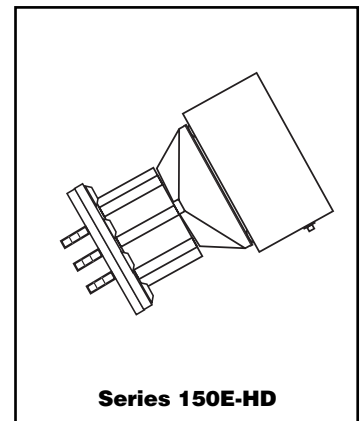
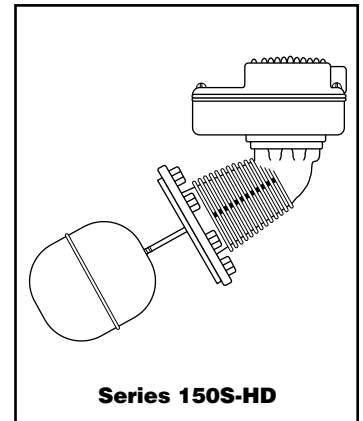



Low Water Cut-Off/Pump Controllers For Steam Boilers

Series 150, 150S & 150E Series 157, 157S & 157E (continued)

IMPORTANT:

- Snap switches **must** be replaced as an assembly.
- We recommend complete head replacement to eliminate the need for field adjustment of the switch assembly.
- Series 150S and 157S replacement switch assemblies are not interchangeable with Series 150 and 157 mercury switch controls.

Note:
Manual reset models with date code 03K (October 2003) or older require the purchase of a new head.

Replacement Switch Assemblies for Series 150S and 157S

For Model	Repl. Switch Model No.	Part Number	Description	Weight lbs. (kg)
All 150S & 157S Units Except 'MD' Models	SWA-150S	310462	Snap-action switch assembly	0.5 (.23)
All 150S & 157S 'MD' Models	SWA-150S-MD	310464	Snap-action switch assembly for maximum differential models	0.5 (.23)
All 158S Models	SWA-158S	310468	Snap-action switch assembly for Model 158S	0.5 (.23)
All 159S Models	SWA-159S	310470	Snap-action switch assembly	0.5 (.23)

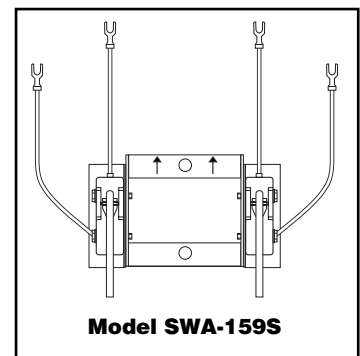
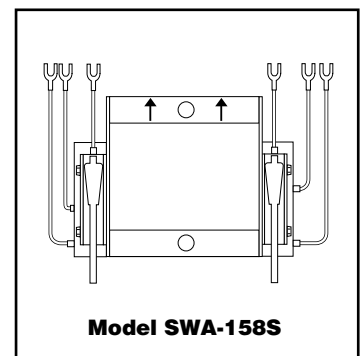
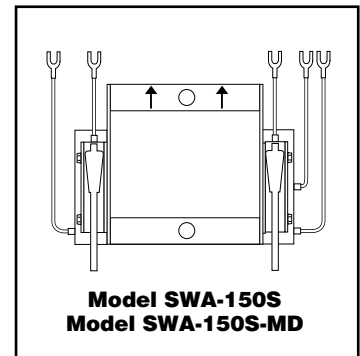

Switch assemblies include a mounting bracket and color-coded terminal connection wires.



Low Water Cut-Off/Pump Controllers For Steam Boilers

Series 150, 150S & 150E Series 157, 157S & 157E (continued)

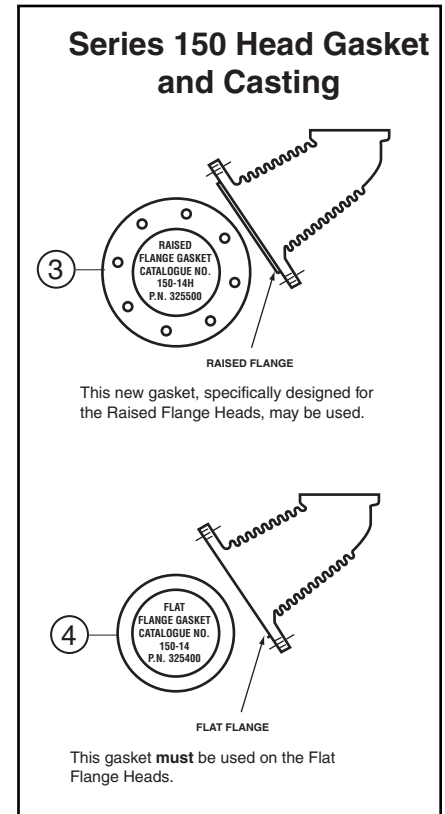
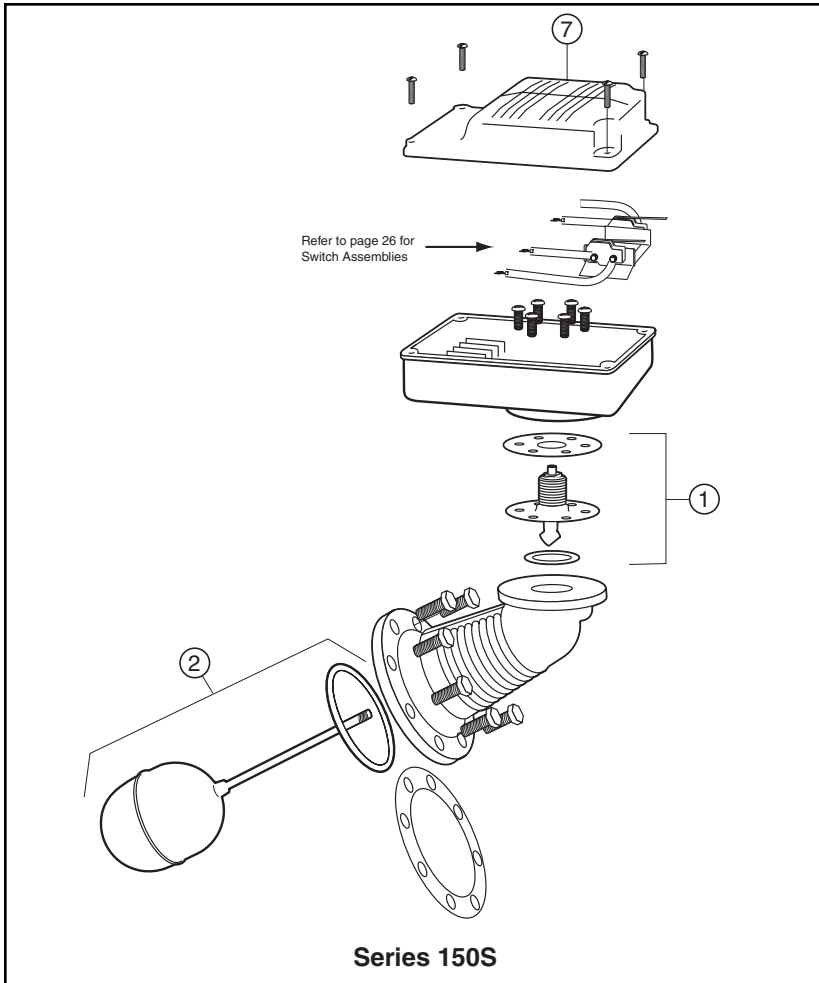

Components

Item Number	Model Number	Part Number	Description	Weight lbs. (kg)
1	SA150-106R	347900	Bellows assembly	0.4 (.18)
2	SA150-11	347600	Float & rod	1.0 (0.5)
3	150-14H	325500	Head gasket for raised face flange head, 8 holes	0.5 (.23)
4	150-14	325400	Head gasket for flat face flange head, no holes	0.5 (.23)
7	150-436	326950	Cover	.435 (.19)



Low Water Cut-Off/Pump Controllers For Steam Boilers

Series 150, 150S & 150E Series 157, 157S & 157E (continued)

Components

Item Number	Model Number	Part Number	Description	Weight lbs. (kg)
1	150E-PF	310492	Flange/Probe assembly	5.38 (2.51)
2	150E-CU	310490	Control unit, automatic reset	2.07 (.96)
2	150M-CU	310491	Control unit, manual reset	2.07 (.96)
3	150-14H	325500	Gasket (for raised face head flange, 8 holes)	0.5 (.23)

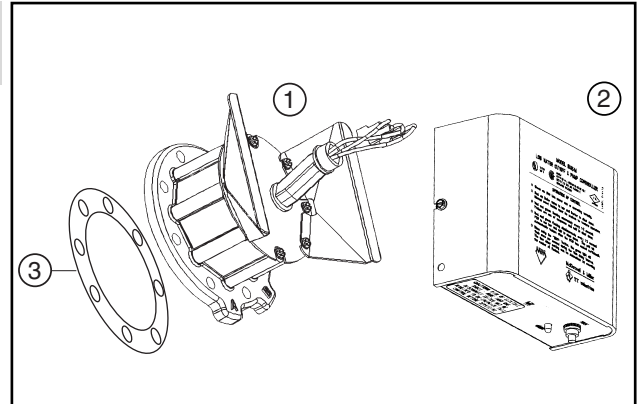

Components

Item Number	Model Number	Part Number	Description	Weight lbs. (kg)
4	EA-157-S	354106	Short electrode for 157S-RBP	0.5 (.23)
5	EA-157-L	354107	Long electrode for 157S-RBP	0.5 (.23)

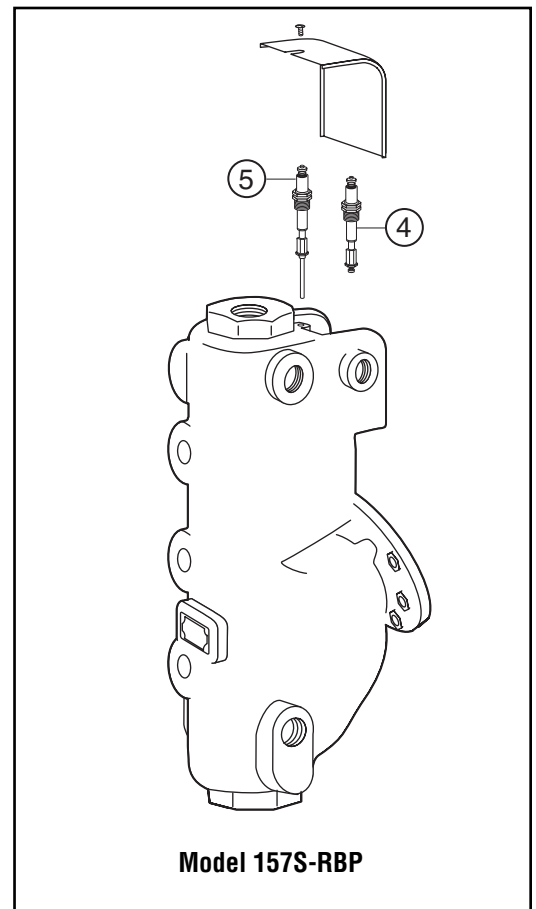



Water Feeders – Electric

Series WF2 Uni-Match® Electric Water Feeders

Components

Item Number	Part Number	Model Number	Description	Weight lbs. (kg)
1	310473	STR-WF2	Strainer/orifice kit	0.1 (.05)

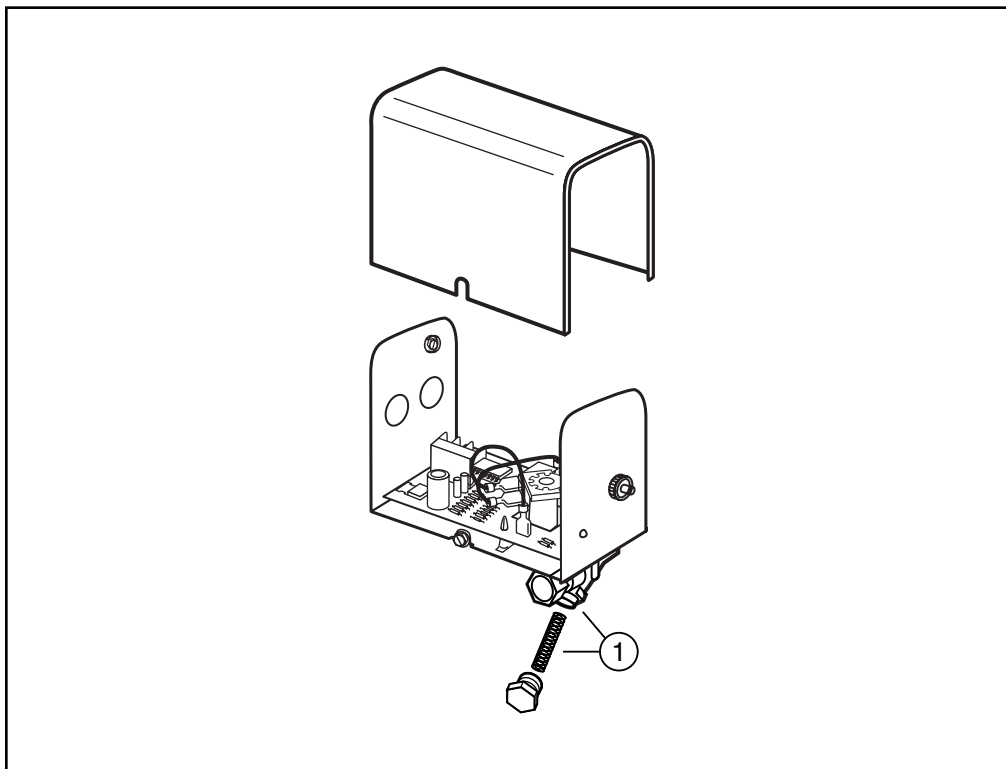



Water Feeders – Electric

Series 101-A Electric Water Feeders



Series 101-A

Components

Item Number	Part Number	Model Number	Description	Weight lbs. (kg)
1	310453	CTRD-101	Cartridge & strainer kit	0.8 (.36)
2	324435	37-101	Tetraseal O-ring	0.1 (.05)
3	324100	101-24V-48	Transformer (24V)	3.5 (1.6)
4	347100	SA-101-38	Strainer (includes item 2)	0.7 (.32)

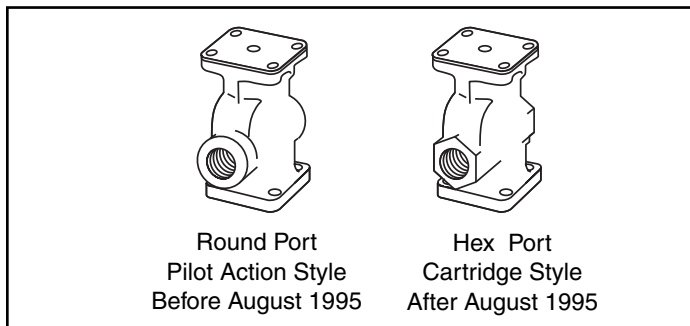
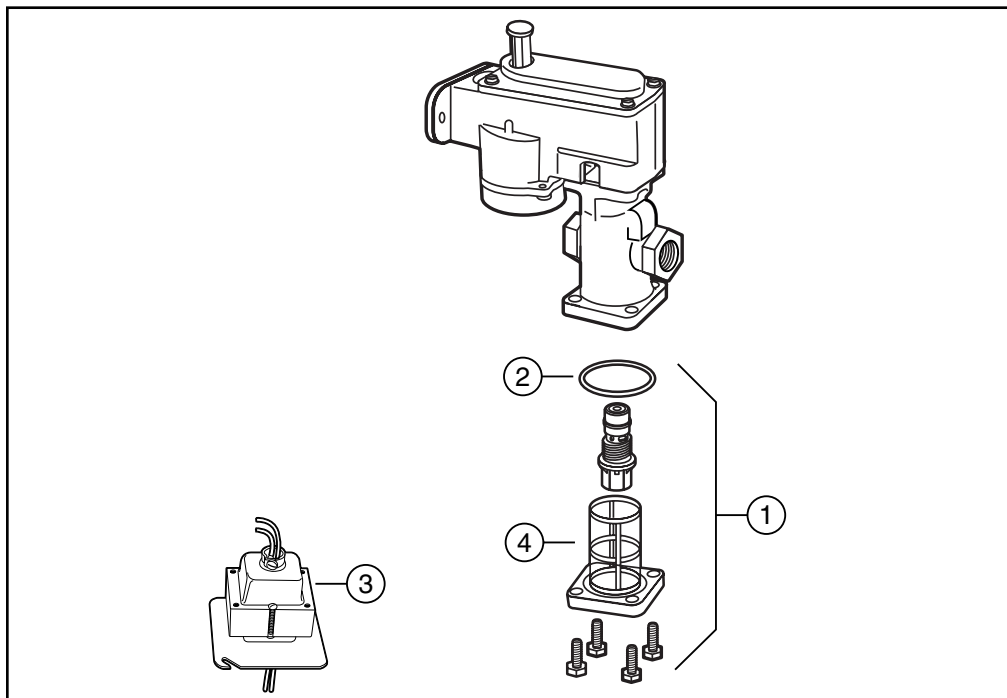



Water Feeders – Make-Up

Series 21 Make-Up Water Feeders

Components

Item Number	Part Number	Model Number	Description	Weight lbs. (kg)
1	311200	21-30	Float (includes item 2)	1.7 (.77)
2	335400	847-26	Gasket	0.1 (.05)
3	311100	21-27	Gasket	0.1 (.05)
4	310800	21-12	Gasket	0.1 (.05)
5	339500	SA21-6	Valve assembly (includes items 2, 3, 4 & 6)	3.0 (1.4)
6	312900	37-28	Gasket	0.1 (.05)
7	342300	SA51-9R	Strainer assembly	3.0 (1.4)
8	339700	SA21-38R	Strainer basket (includes item 9)	1.0 (0.5)
9	324435	37-101	Tetraseal O-ring	0.1 (.05)
10	311400	21-109	Connector	0.1 (.05)
11	310600	21-3	Bracket	2.5 (1.1)

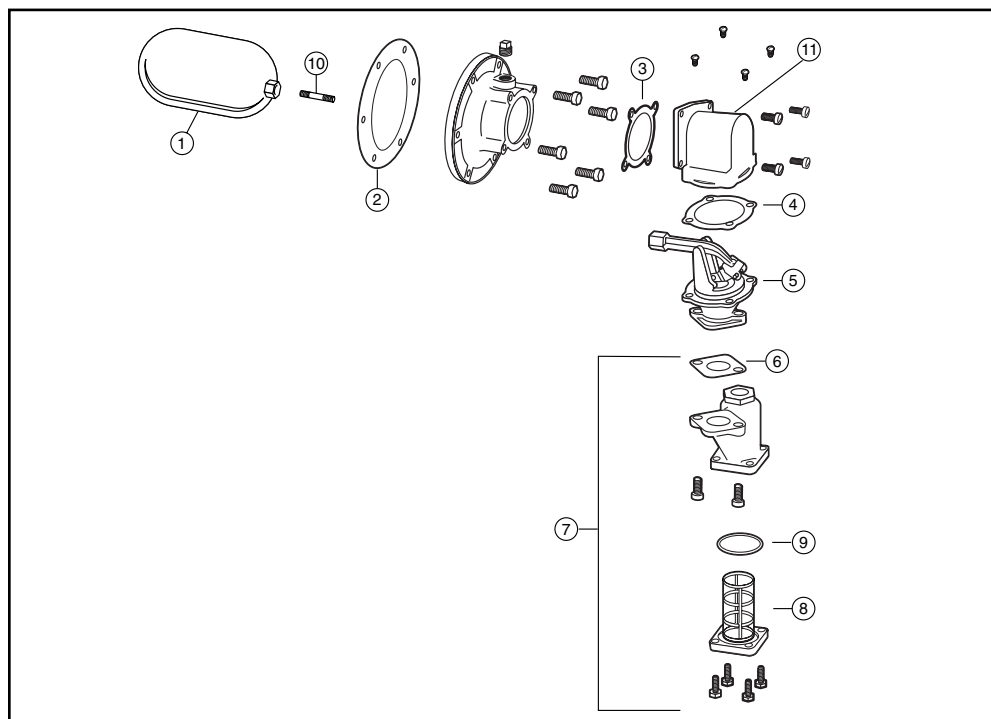



Water Feeders – Make-Up

Series 25-A Make-Up Water Feeders

Replacement Head Mechanisms

For Series	Repl. Head Model No.	Part Number	Description	Weight lbs. (kg)
25-A	25A-HD	127100	Head mechanism	20 (9.1)

Components

Item Number	Part Number	Model Number	Description	Weight lbs. (kg)
1	304100	F-26	Gasket	0.1 (.05)
2	334100	421-30	Float (includes item 2)	1.5 (0.7)
3	340400	SA27T-75	Diaphragm seal assembly (includes item 1)	0.1 (.05)
4	339800	SA25-5	Arm assembly	0.1 (.05)
5	311100	21-27	Gasket	0.1 (.05)
6	312900	37-28	Gasket	0.1 (.05)
7	342300	SA51-9R	Strainer assembly (includes item 6)	3.0 (1.4)
8	324435	37-101	Tetraseal O-ring	0.1 (.05)
9	339700	SA21-38R	Strainer basket (includes item 8)	1.0 (0.5)
10	339900	SA25A-6	Valve assembly	3.0 (1.4)
11	340000	SA25A-15	Stem, disc & seat assembly (includes item 6)	0.3 (.14)
12	311900	27T-9	Float Rod	0.1 (.05)

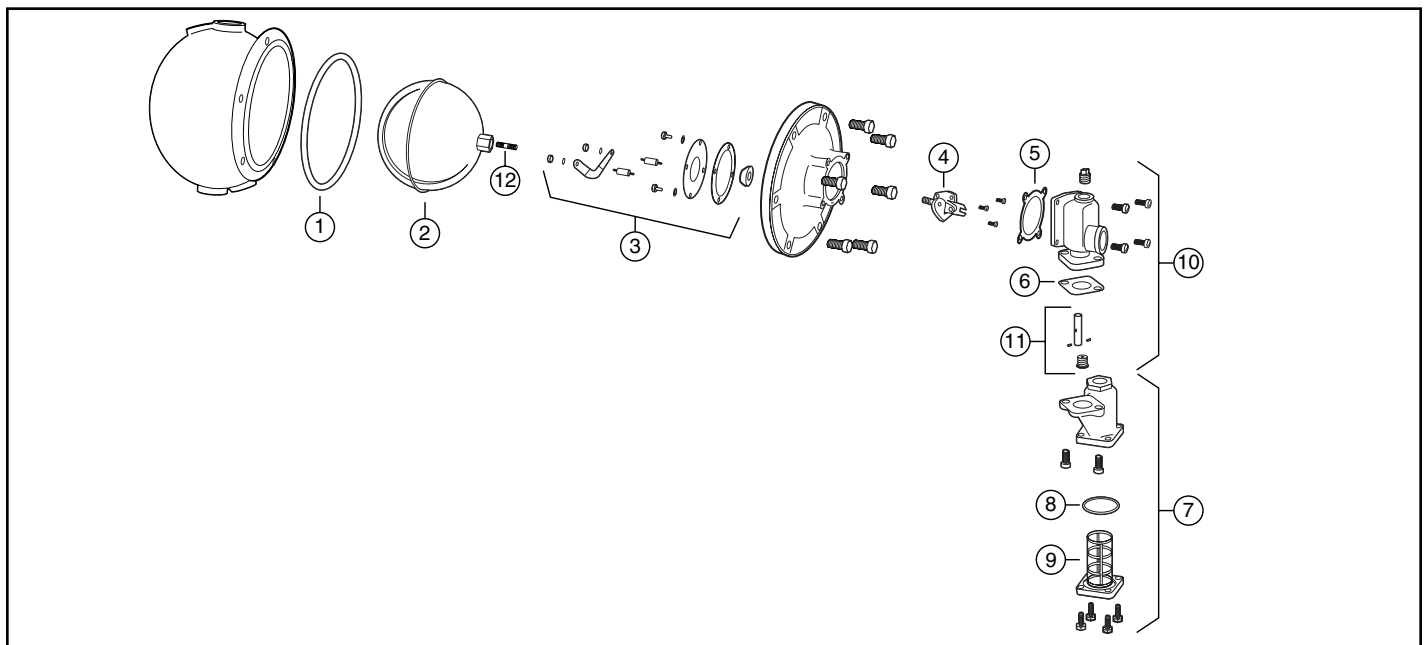
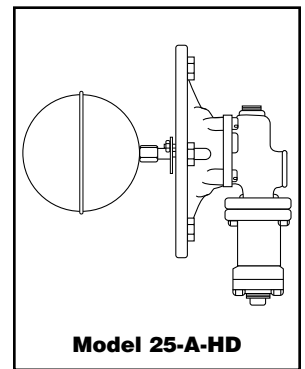



Water Feeders – Make-Up

Series 221 Make-Up Water Feeders

Components

Item Number	Part Number	Model Number	Description	Weight lbs. (kg)
1	311200	21-30	Float (includes item 2)	1.7 (.77)
2	304100	F-26	Gasket	0.1 (.05)
3	311100	21-27	Gasket	0.1 (.05)
4	310800	21-12	Gasket	0.1 (.05)
5	339500	SA21-6	Valve assembly (includes 2,3,4,6)	3.0 (1.4)
6	312900	37-28	Gasket	0.1 (.05)
7	342300	SA51-9R	Strainer assembly	3.0 (1.4)
8	339700	SA21-38R	Strainer basket (includes item 9)	1.0 (0.5)
9	324435	37-101	Tetraseal O-ring	0.1 (.05)
10	311400	21-109	Connector	0.1 (.05)
11	310600	21-3	Bracket	2.5 (1.1)

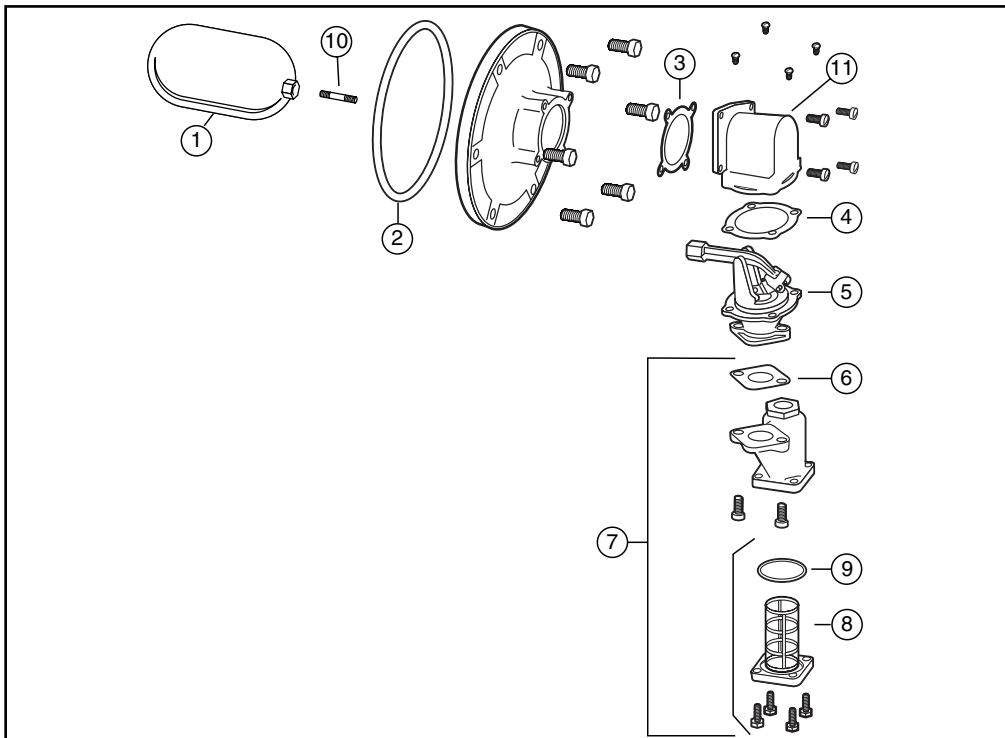



Water Feeders – Make-Up

Series 551-S Make-Up Water Feeders

Replacement Head Mechanisms

For Series	Repl. Head Model No.	Part Number	Description	Weight lbs. (kg)
551-S	551S-HD	136600	Head mechanism	25.7 (11.7)

Components

Item Number	Part Number	Model Number	Description	Weight lbs. (kg)
1	310437	FLT-51-05	Float (includes item 2) (see note below)	2.5 (1.1)
2	304100	F-26	Gasket	0.1 (.05)
3	310442	BA-551-05	Bellows bracket assembly (see note below)	1.5 (0.7)
4	312800	37-27	Gasket	0.1 (.05)
5*	352600	SA551S-101-102	Valve & strainer kit	4.0 (1.8)
6	324435	37-101	Tetraseal o-ring	0.1 (.05)
7	347100	SA101-38	Strainer basket (includes item 6)	0.7 (.32)
8	310452	CTRD-51	Cartridge kit	0.8 (.36)

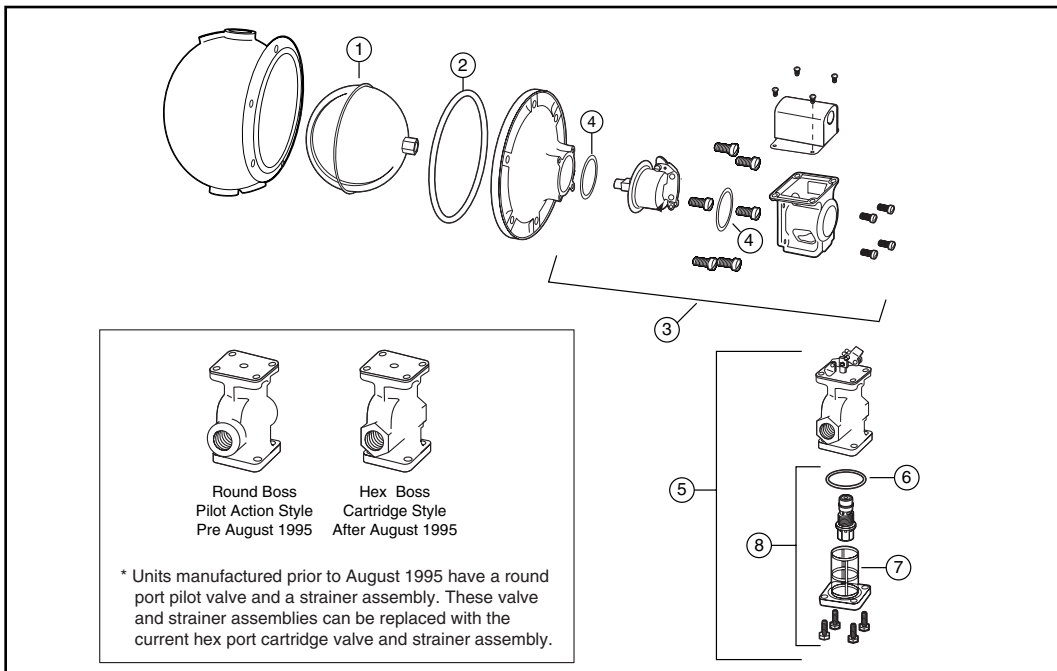
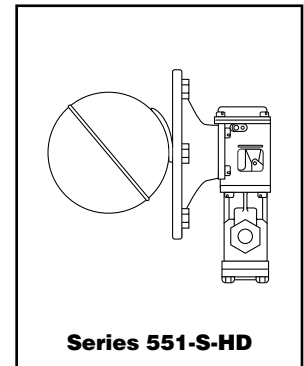

NOTE:
One time float and bellows replacement is required when replacing bellows or float assemblies with date codes before February 2005 (05B).



Water Feeders – Make-Up

Series 847 Make-Up Water Feeders

Components

Item Number	Part Number	Model Number	Description	Weight lbs. (kg)
1	313600	37A-130	Float (includes item 2)	2.0 (0.9)
2	335400	847-26	Gasket	0.1 (.05)
3	352800	SA847-4	Bellows bracket assembly (includes item 2 and 4)	1.5 (0.7)
4	312800	37-27	Gasket	0.1 (.05)
5*	341600	SA47-101-102	Valve & strainer kit	3.0 (1.4)
6	324435	37-101	Tetraseal O-ring	0.1 (.05)
7	347100	SA101-38	Strainer basket (includes item 6)	0.7 (.32)
8	310453	CTRD-101	Cartridge & strainer kit	0.8 (.36)
9	110000	2	Switch	1.0 (0.5)
10	312600	37-20	Cover	0.1 (.05)

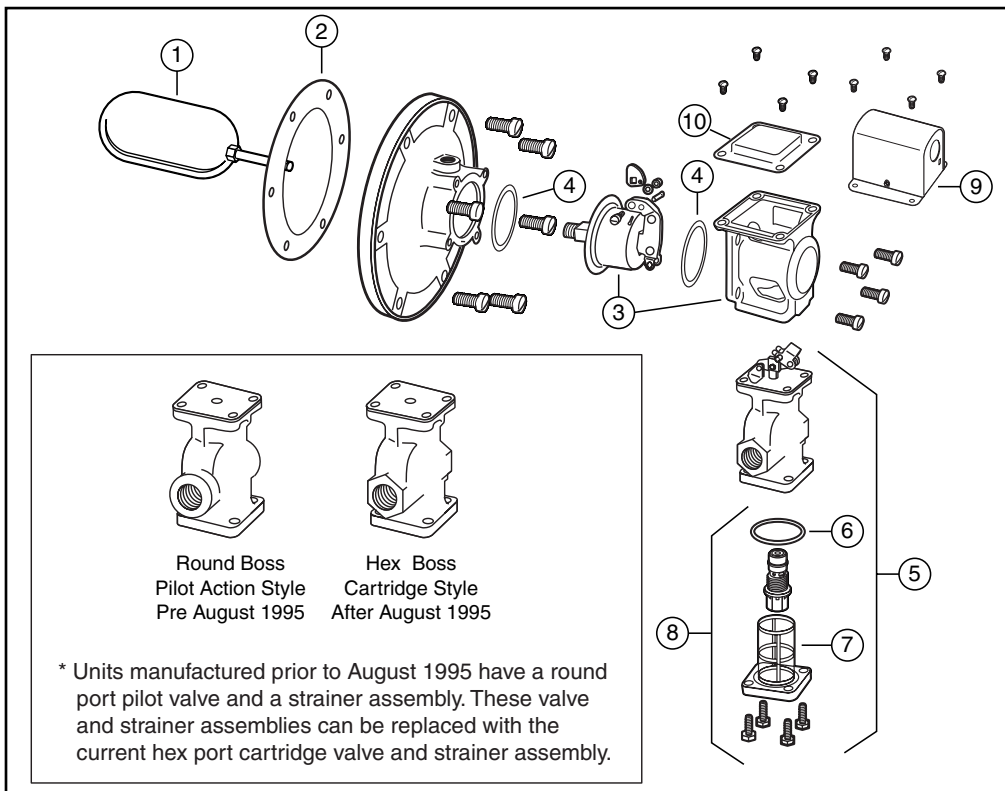



Water Feeders – Make-Up

Series 851 Make-Up Water Feeders

Components

Item Number	Part Number	Model Number	Description	Weight lbs. (kg)
1	313600	37A-130	Float (includes item 2)	2.0 (0.9)
2	335400	847-26	Gasket	0.1 (.05)
3	352925	SA851-4	Bellows bracket assembly	1.5 (0.7)
4	312800	37-27	Gasket	0.1 (.05)
5*	342500	SA51-101-102	Valve & strainer kit	3.0 (1.4)
6	324435	37-101	Tetraseal O-ring	0.1 (.05)
7	347100	SA101-38	Strainer basket (includes item 6)	0.7 (.32)
8	310452	CTRD-51	Cartridge & strainer kit	0.8 (.36)
9	335700	851-105	Float rod	0.3 (.14)
10	110000	2	Switch	1.0 (.05)
11	312600	37-20	Cover	0.1 (.05)

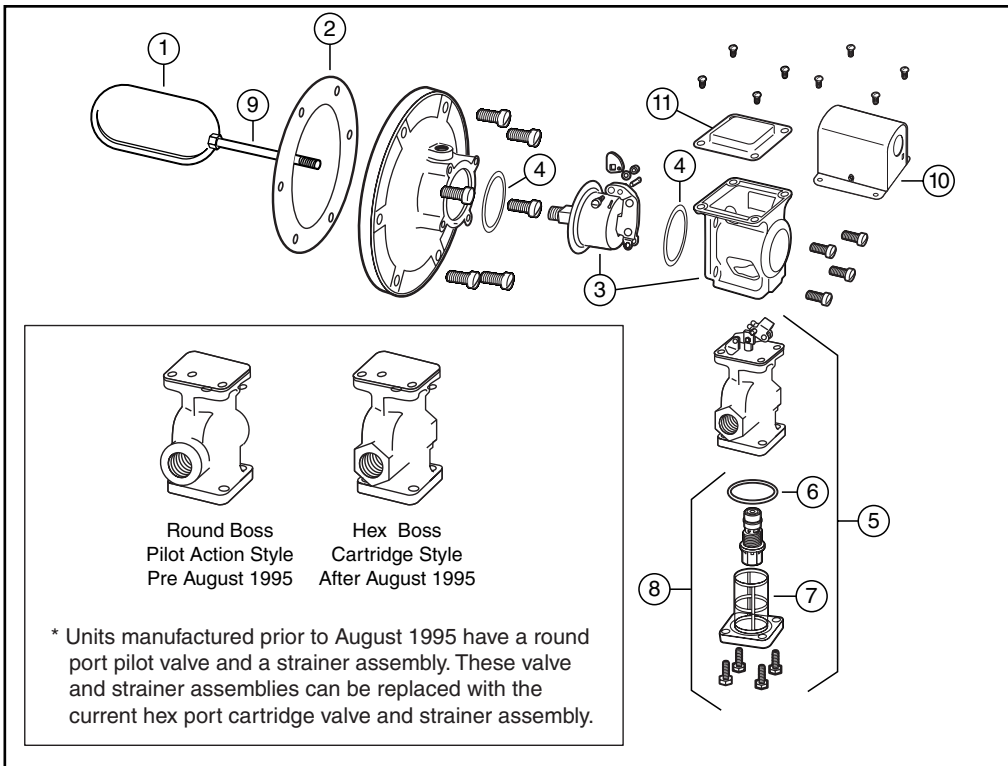



Water Feeders – Make-Up

Series 851-S Make-Up Water Feeders

Components

Item Number	Part Number	Model Number	Description	Weight lbs. (kg)
1	313600	37A-130	Float (includes item 2)	2.0 (.9)
2	335400	847-26	Gasket	0.1 (.05)
3	352925	SA851-4	Bellows bracket assembly (includes item 4)	1.5 (.7)
4	312800	37-27	Gasket	0.1 (.05)
5	342100	SA51S-6	Valve assembly	3.0 (1.4)
6	316200	51S-114	Valve seat	0.1 (.05)
7	312900	37-28	Gasket	0.1 (.05)
8	324435	37-101	Tetraseal O-ring	0.1 (.05)
9	340700	SA37-38	Strainer basket (includes item 8))	0.7 (.32)
10	342200	SA51-9	Strainer assembly	3.0 (1.4)
11	335750	851S-105	Float rod	0.3 (.14)
12	110000	2	Switch	1.0 (0.5)
13	312600	37-20	Cover	0.1 (0.5)

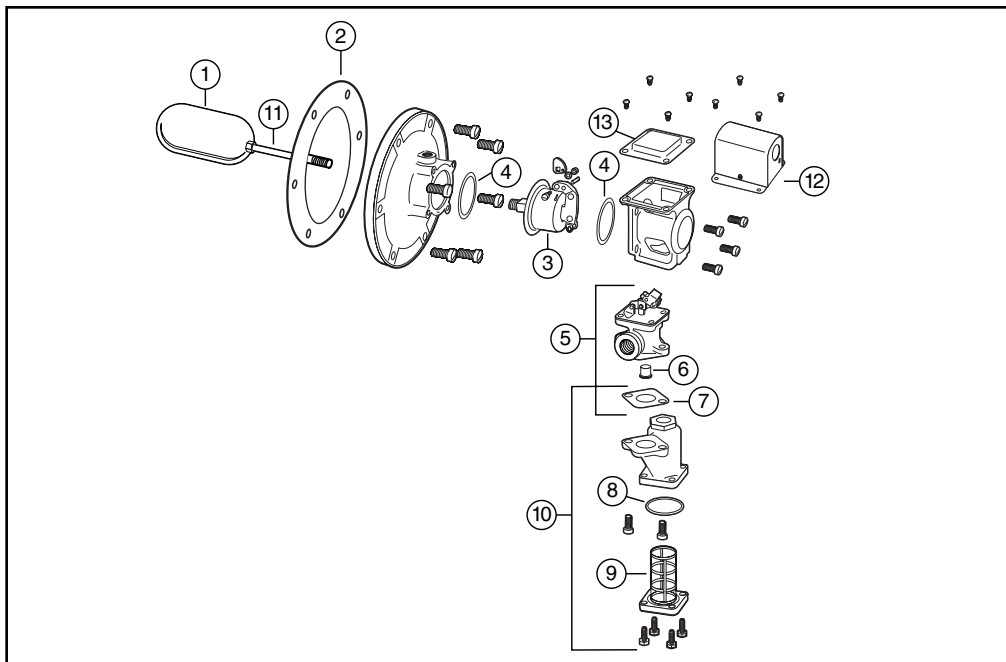



BOILER CONTROLS

Combination Mechanical Water Feeder/ Low Water Cut-Offs

Series 47/47-2

Mechanical Water Feeder/Low Water Cut-Offs

Components (shown on page 39)

Item Number	Part Number	Model Number	Description	Weight lbs. (kg)
1	310453	CTRD-101	Cartridge and strainer kit	.35 (.16)
2*	341600	SA47-101-102	Valve, cartridge & strainer assembly kit	3.0 (1.4)
3	324435	37-101	Tetraseal o-ring	0.1 (.05)
4	347100	SA101-38	Strainer for hex port valves (includes item 3)	0.7 (.32)
5	341500	SA47-4	Bellows and bracket assembly (includes item 15)	1.5 (0.7)
6	312800	37-27	Gasket	0.1 (.05)
7	302900	CO-106	Cam assembly	0.1 (.05)
8	110000	2	Switch	1.0 (0.5)
9	110100	2-M	Switch with manual reset	1.0 (0.5)
10	332800	MA-259	Quick hook-up fittings (includes item 11, 12, 13)	4.5 (2.0)
11	349400	SA159-17	Black "Y" assembly	2.3 (1.0)
12	351800	SA259-24	Upper quick hook-up fittings	1.7 (.77)
13	349500	SA159-24	Lower quick hook-up fittings	1.7 (.77)
14	340600	SA37-30	Float assembly	2.0 (0.9)
15	312700	37-26	Gasket	0.1 (.05)
16	310447	14-B	Blow-down valve (includes item 17)	1.5 (0.7)
17	313200	37-39	Blow-down valve gasket	1.0 (0.5)





Round Port
Pilot Action Style
Before August 1995



Hex Port
Cartridge Style
After August 1995

* Units manufactured prior to August 1995 have a round port pilot valve and a strainer assembly. These valve and strainer assemblies can be replaced with the current hex port cartridge valve and strainer assembly.



Combination Mechanical Water Feeder/ Low Water Cut-Offs

Series 47/47-2 (continued)

Mechanical Water Feeder/Low Water Cut-Offs

Components

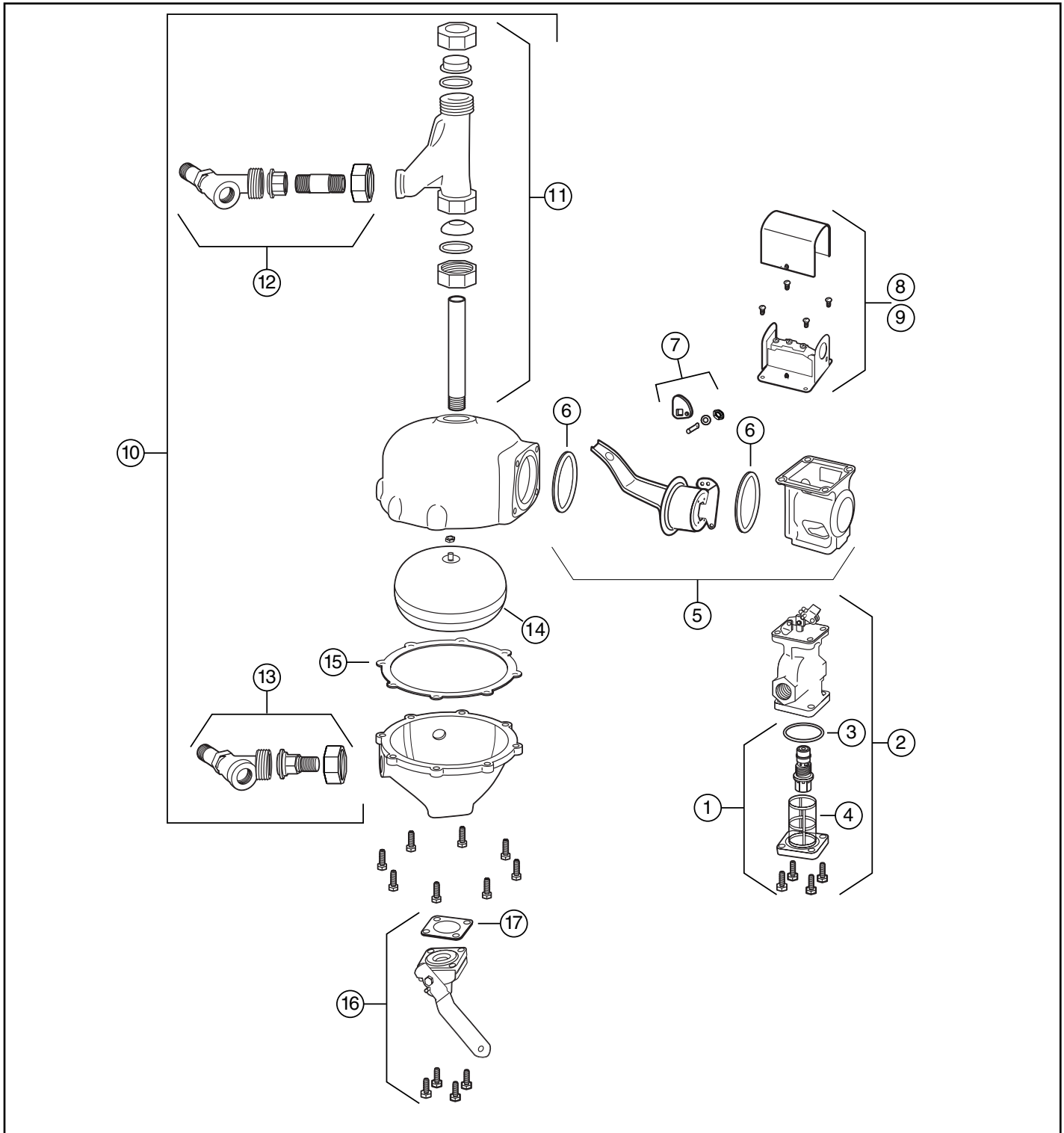



BOILER CONTROLS

Combination Mechanical Water Feeder/ Low Water Cut-Offs

Series 247/247-2

Mechanical Water Feeder/Low Water Cut-Offs

Components (shown on page 41)

Item Number	Part Number	Model Number	Description	Weight lbs. (kg)
1	310453	CTRD-101	Cartridge & strainer kit	.35 (.16)
2*	341600	SA47-101-102	Valve, cartridge & strainer assembly kit	3.0 (1.4)
3	324435	37-101	Tetraseal o-ring	0.1 (.05)
4	347100	SA101-38	Strainer for hex port valves (includes item 3)	0.2 (.09)
5	341900	SA47-104	Bellows & bracket assembly (includes item 11)	1.5 (0.7)
6	312800	37-27	Gasket	0.1 (.05)
7	302900	CO-106	Cam assembly	0.1 (.05)
8	110000	2	Switch	1.0 (0.5)
9	110100	2-M	Switch w/manual reset	1.0 (0.5)
10	340600	SA37-30	Float assembly	2.0 (0.9)
11	312700	37-26	Gasket	0.1 (.05)





Round Boss
Pilot Action Style
Pre August 1995



Hex Boss
Cartridge Style
After August 1995

* Units manufactured prior to August 1995 have a round port pilot valve and a strainer assembly. These valve and strainer assemblies can be replaced with the current hex port cartridge valve and strainer assembly.



Combination Mechanical Water Feeder/ Low Water Cut-Offs

Series 247/247-2 (continued)

Mechanical Water Feeder/Low Water Cut-Offs

Components

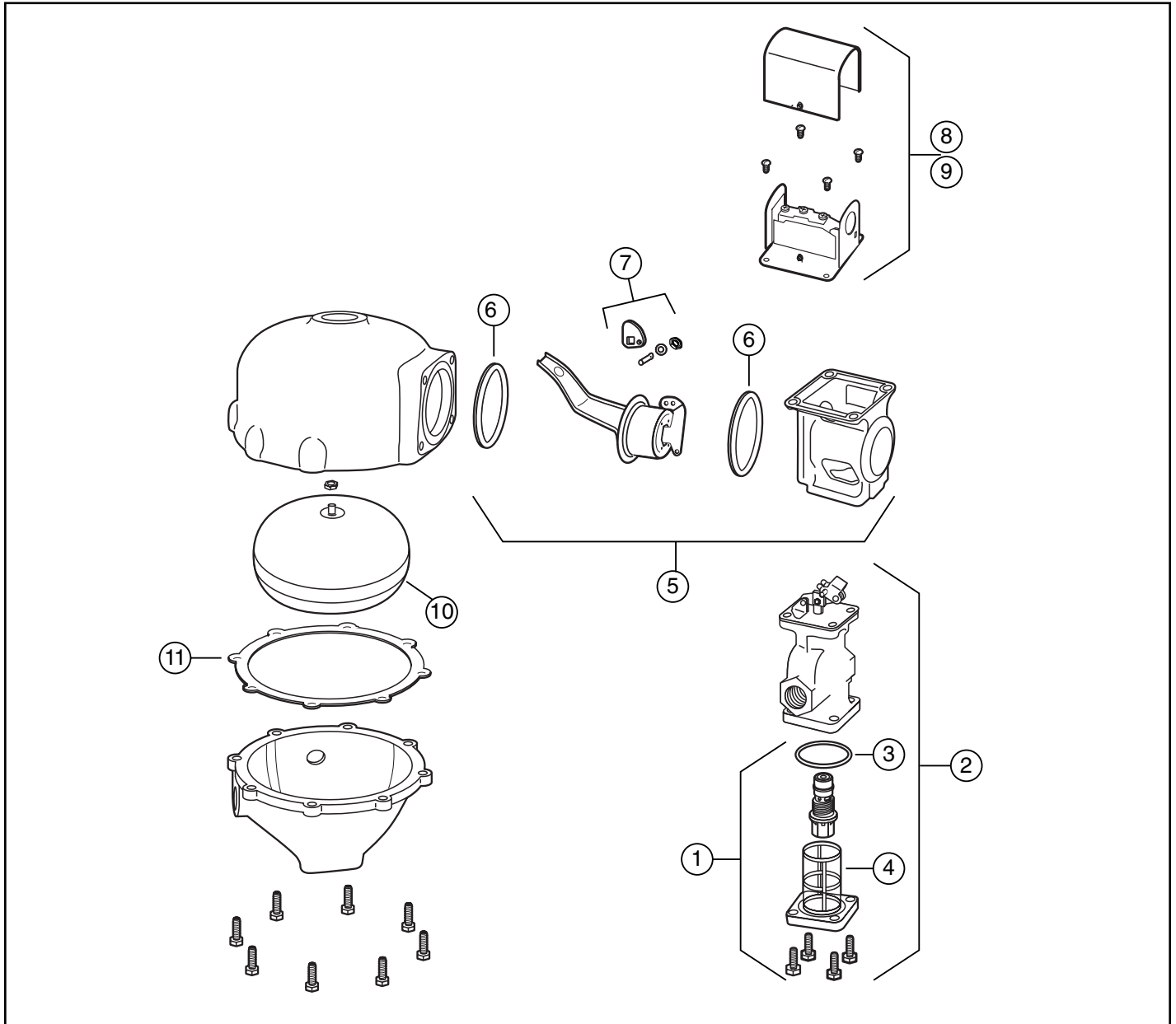



BOILER CONTROLS

Combination Mechanical Water Feeder/ Low Water Cut-Offs

Series 51/51-2

Water Feeder/Low Water Cut-Offs



Series 51



Series 51-2

Replacement Head Mechanisms

For Series	Repl. Head Model No.	Part Number	Description	Weight lbs. (kg)
51-2	51-2-HD or	135100	Head mechanism w/ No. 2 switch	18.3 (8.3)
	51-2M-HD	135300	51-2-HD w/manual reset	26.0 (11.8)

Components (shown on page 43)

Item	Part	Model	Description	Weight
1	110000	2	Low water cut-off switch	1.0 (0.5)
2	110100	2-M	No. 2 w/manual reset	1.0 (0.5)
3	310437	FLT-51-05	Float (see note following page)	2.5 (1.1)
4	304100	F-26	Gasket	0.1 (.05)
5	312800	37-27	Gasket	0.1 (.05)
6	302900	CO-106	Cam assembly	0.1 (.05)
7	310439	BA-51-05	Bellows bracket assembly (includes item 4) (see note following page)	1.5 (0.7)
8*	342500	SA51-101-102	Valve & strainer kit	3.0 (1.4)
9	310452	CTRD-51	Cartridge & strainer kit	0.8 (.36)
10	324435	37-101	Tetraseal O-ring	0.1 (.05)
11	347100	SA101-38	Strainer basket (includes item 10)	0.7 (.32)

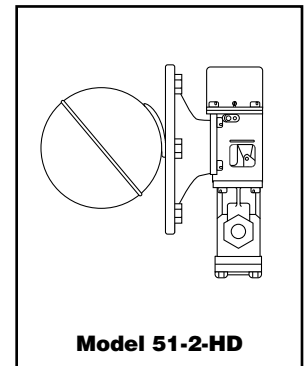

Model 51-2-HD



Combination Mechanical Water Feeder/ Low Water Cut-Offs

Series 51/51-2 (continued)

Water Feeder/Low Water Cut-Offs

Components

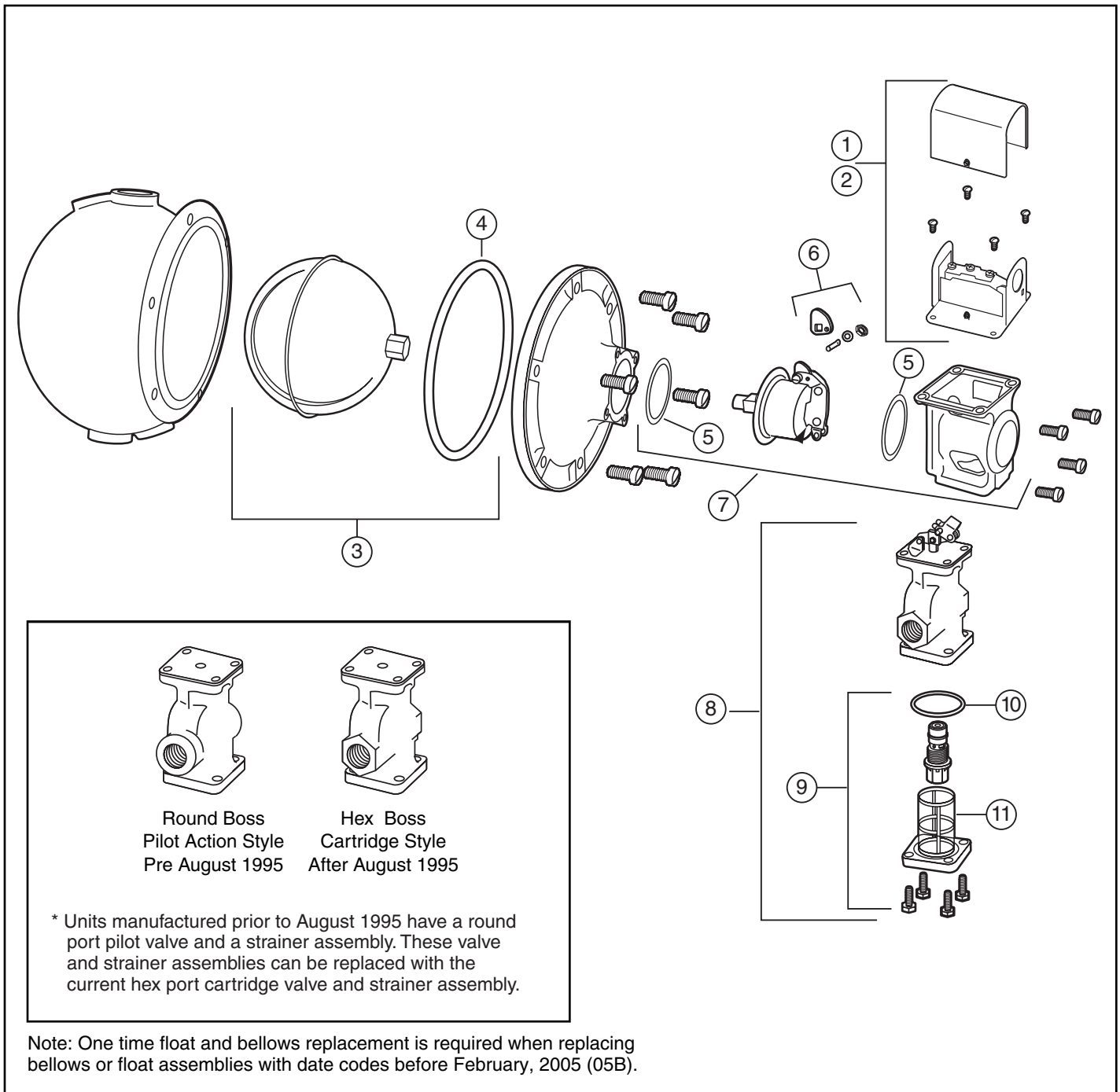



Combination Mechanical Water Feeder/ Low Water Cut-Offs

Series 51-S/51-S-2 Water Feeder/Low Water Cut-Offs

Replacement Head Mechanisms

For Series	Repl. Head Model No.	Part Number	Description	Weight lbs. (kg)
51-S	51-S-2-HD or	136200	Head mechanism w/ No. 2 switch	20.5 (9.3)
	51-S-2M-HD	136250	51-S-2-HD w/manual reset	21.7 (9.8)

Components (shown on page 45)

Item Number	Part Number	Model Number	Description	Weight lbs. (kg)
1	110000	2	Low water cut-off switch	1.0 (0.5)
2	110100	2-M	No. 2 w/manual reset	1.0 (0.5)
3	310437	FLT-51-05	Float (see note following page)	2.5 (1.1)
4	304100	F-26	Gasket	0.1 (.05)
5	312800	37-27	Gasket	0.1 (.05)
6	302900	CO-106	Cam assembly	0.1 (.05)
7	310439	BA-51-05	Bellows bracket assembly (includes item 4) (see note following page)	1.0 (0.7)
8	342100	SA51S-6	Valve assembly	3.0 (1.4)
9	316200	51S-114	Valve seat	0.8 (.36)
10	342200	SA51-9	Strainer assembly	0.1 (.05)
11	312900	37-28	Gasket	0.1 (.05)
12	324435	37-101	Tetraseal O-ring	0.1 (.05)
13	340700	SA37-38	Strainer basket (includes item 12)	0.7 (.32)

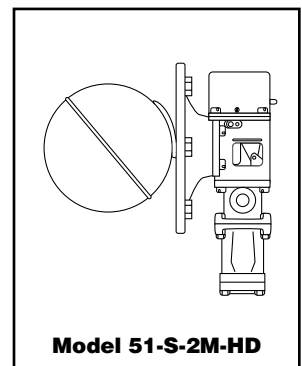
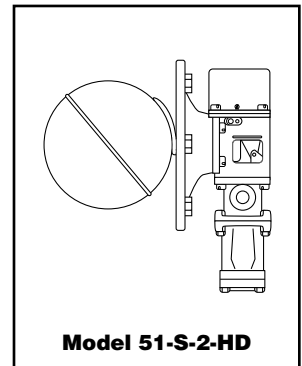



Combination Mechanical Water Feeder/ Low Water Cut-Offs

Series 51-S/51-S-2 (continued)

Water Feeder/Low Water Cut-Offs

Components

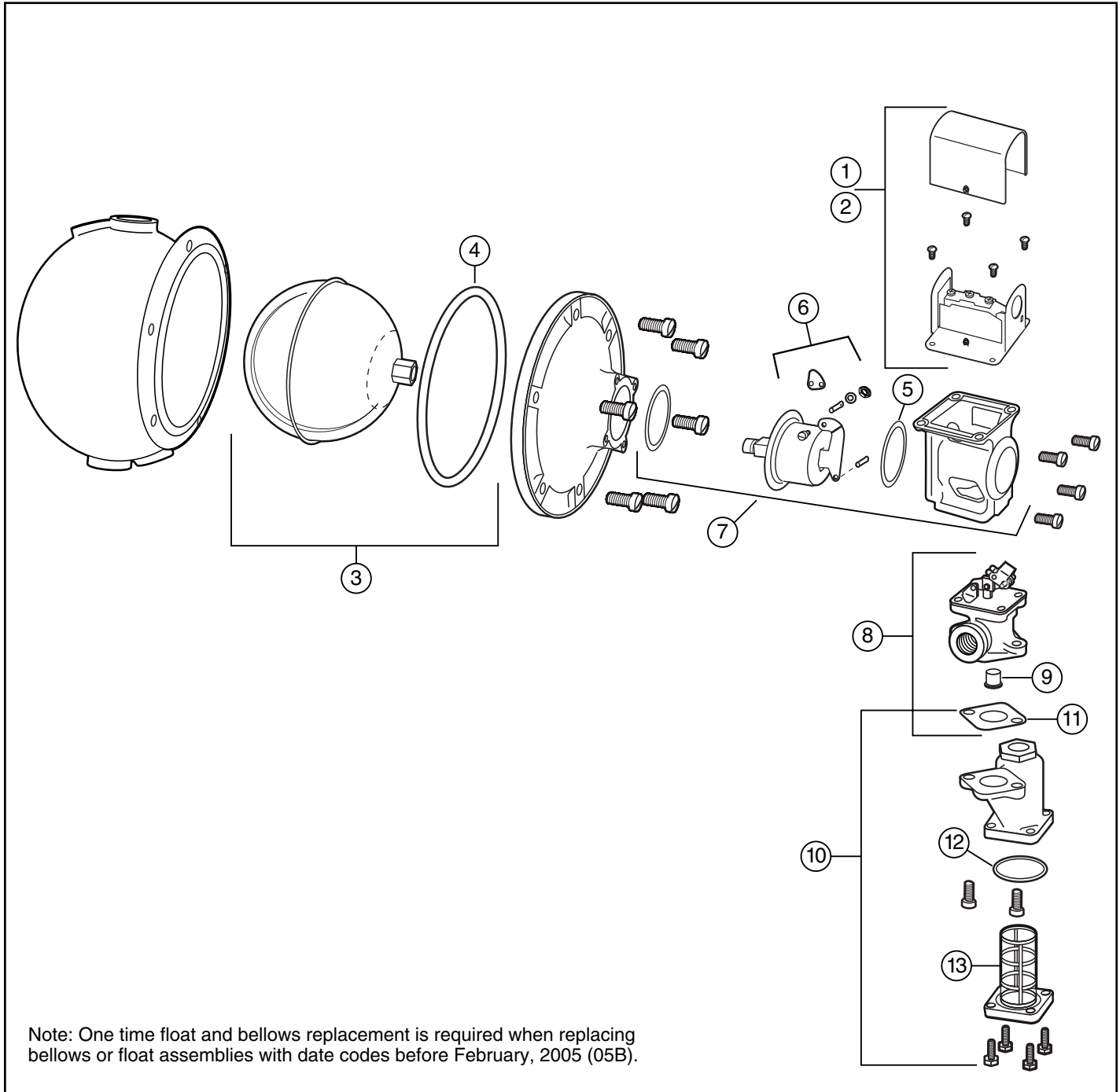

Note: One time float and bellows replacement is required when replacing bellows or float assemblies with date codes before February, 2005 (05B).



Combination Mechanical Water Feeder/ Low Water Cut-Offs

Series 53/53-2

Water Feeder/Low Water Cut-Offs



Series 53



Series 53-2

Replacement Head Mechanisms

For Series	Repl. Head Model No.	Part Number	Description	Weight lbs. (kg)
53	53-2-HD or	137300	Head mechanism w/ No. 2 switch	20.5 (9.3)
	53-2M-HD	137250	53-2-HD w/manual reset	20.5 (9.3)

Components (shown on page 47)

Item Number	Part Number	Model Number	Description	Weight lbs. (kg)
1	110000	2	Low water cut-off switch	1.0 (0.5)
2	110100	2-M	No. 2 w/manual reset	1.0 (0.5)
3	303100	F-26	Gasket	0.1 (.05)
4	310438	FLT-53-05	Float (See note following page)	4.0 (1.8)
5	302900	CO-106	Cam assembly	0.1 (.05)
6	312800	37-27	Gasket	0.1 (.05)
7	310441	BA-53-05	Bellows bracket assembly (includes item 3) (See note following page)	1.5 (0.7)
8	342800	SA53-6	Valve assembly	3.0 (1.4)
9	312900	37-28	Gasket	0.1 (.05)
10	324435	37-101	Tetraseal O-ring	0.1 (.05)
11	340700	SA37-38	Strainer basket	0.7 (.32)

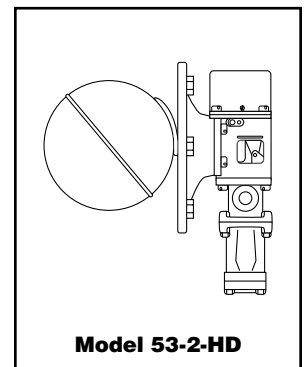

Model 53-2-HD

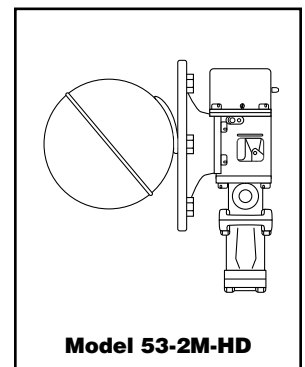

Model 53-2M-HD



Combination Mechanical Water Feeder/ Low Water Cut-Offs

Series 53/53-2 (continued) Water Feeder/Low Water Cut-Offs

Components

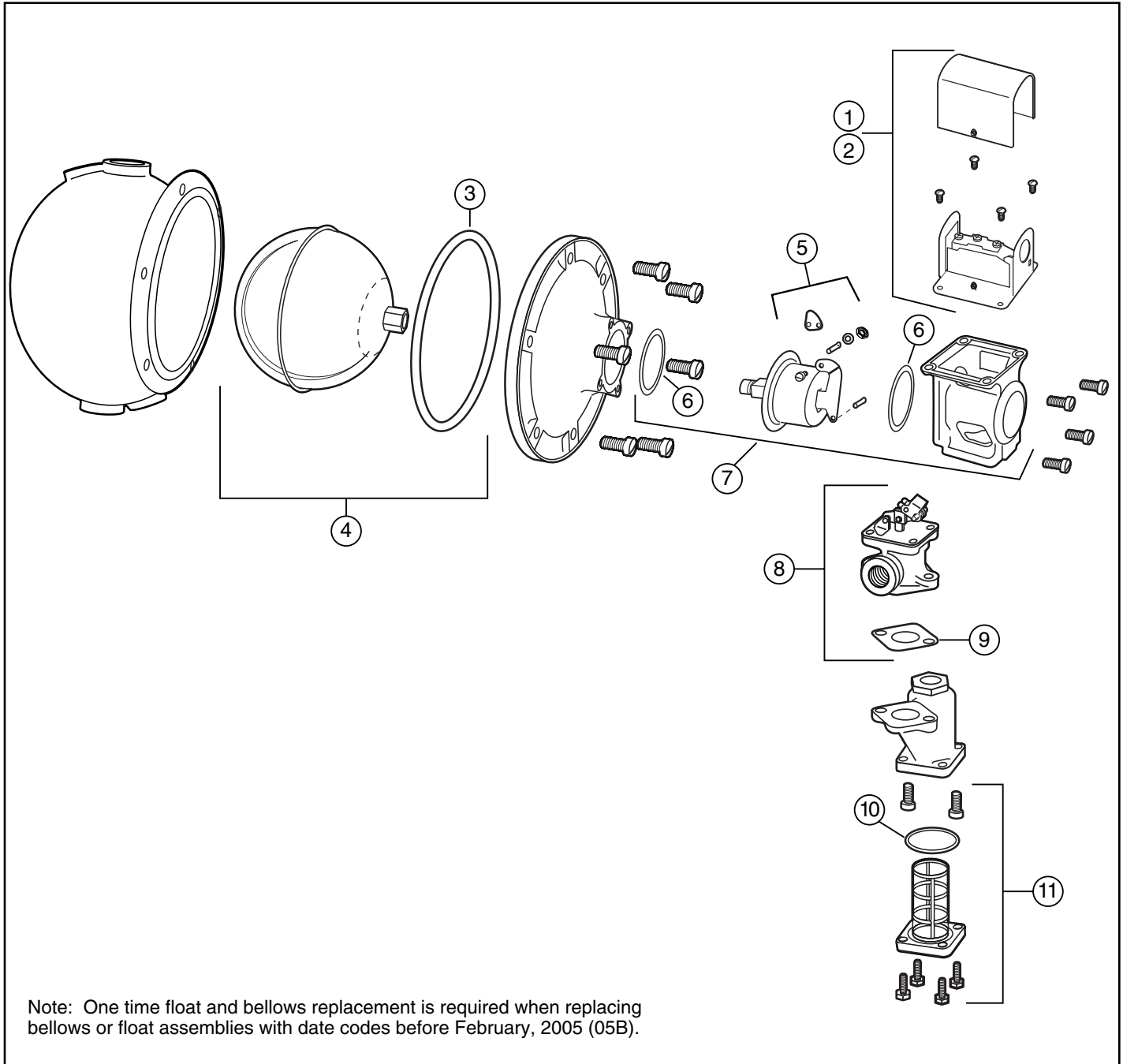

Note: One time float and bellows replacement is required when replacing bellows or float assemblies with date codes before February, 2005 (05B).



Valves

Series TC-4 Test-N-Check® Valves

Components

Item Number	Part Number	Model Number	Description	Weight lbs. (kg)
1	317354	TC-V	Vacuum breaker w/gasket	0.3 (.14)
2	317350	TC-U	Upper valve (includes item 1)	2.7 (1.2)
3	317353	TC-L	Lower valve	2.7 (1.2)

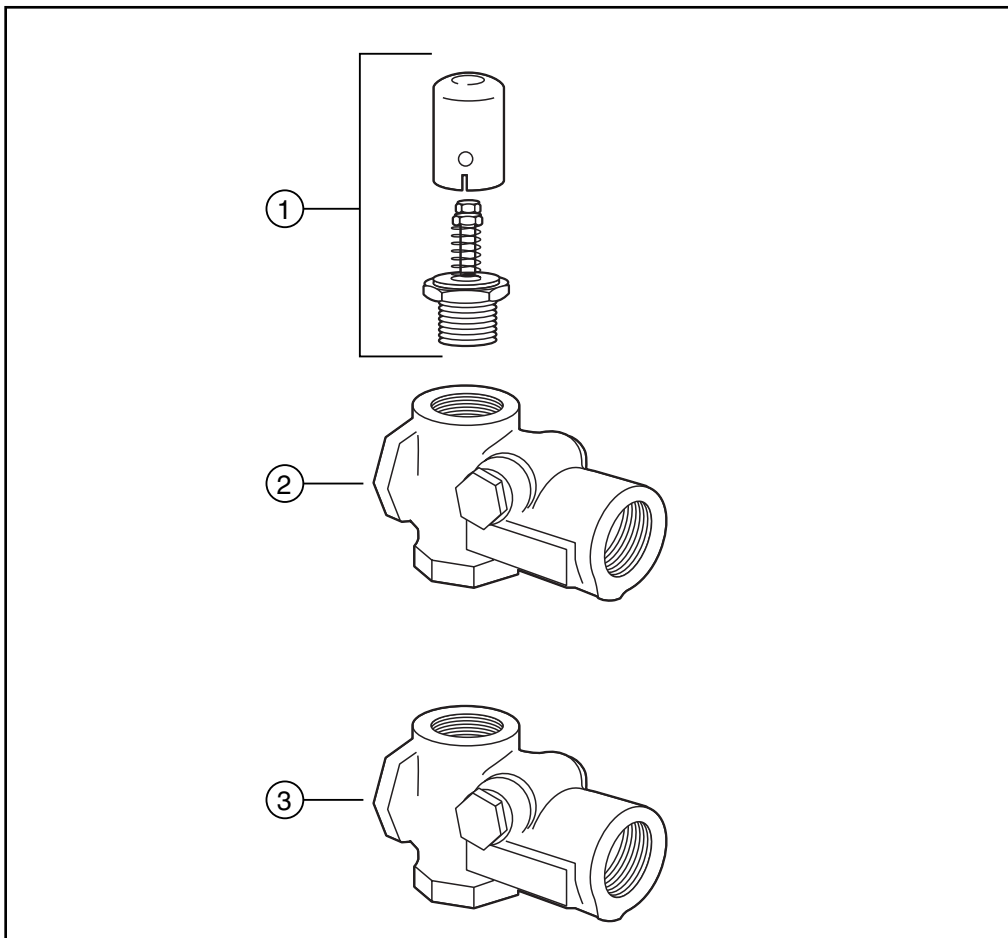



Probe Type Remote Sensors

Components for Remote Sensors

Item Number	Part Number	Model Number	Description	Weight lbs. (kg)
1	354370	GSKT-RS-1	Cover gasket	0.3 (.14)
2	354401	EA-RS	Electrode	0.5 (.23)
3	354081	PA-800	Probe	0.5 (.23)
4	354410	GSKT-RS-2	Cover gasket	0.3 (.14)

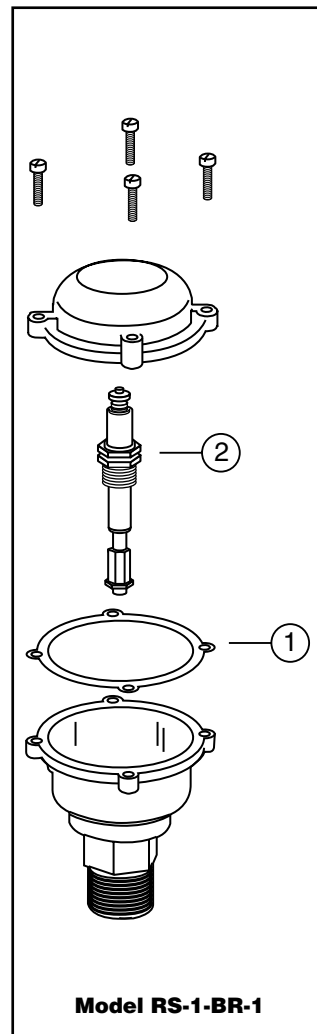
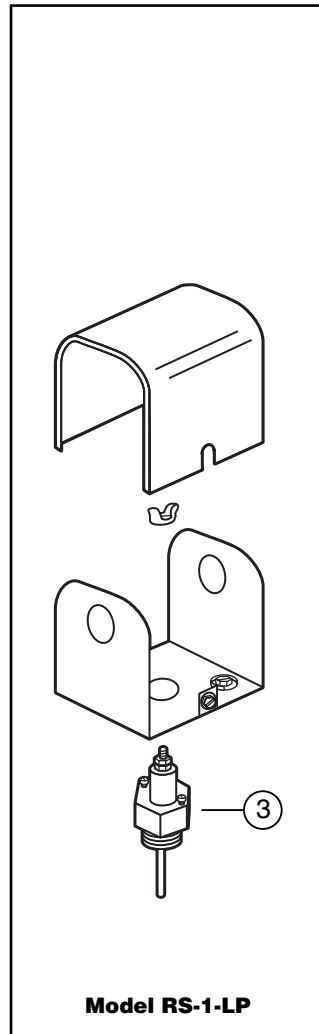
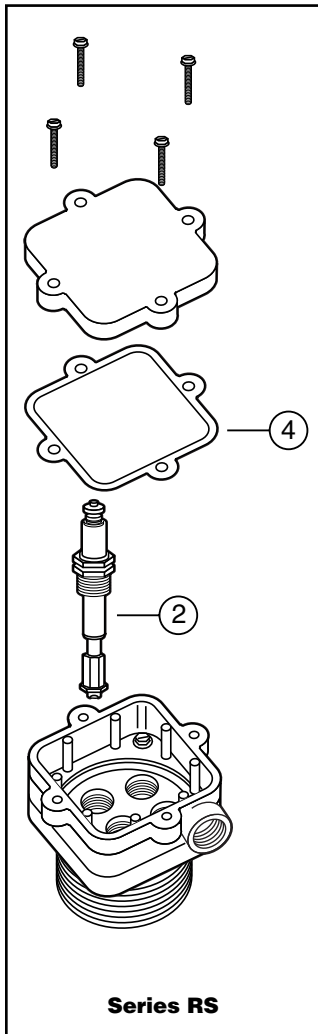



Pneumatic Actuated

Series PFC Liquid Level Controls

Components

Item Number	Part Number	Model Number	Description	Weight lbs. (kg)
1	310471	SWA-PFC-D	Valve assembly-DA	2.0 (0.9)
2	310472	SWA-PFC-R	Valve assembly-RA	2.0 (0.9)
3	354411	G-PFC-S	Supply gauge	0.3 (.14)
4	354412	G-PFC-O	Output gauge	0.3 (.14)
5	354320	FLT-PFC	Float (includes item 6)	0.5 (.23)
6	354310	GSKT-PFC	Gasket	0.2 (.09)

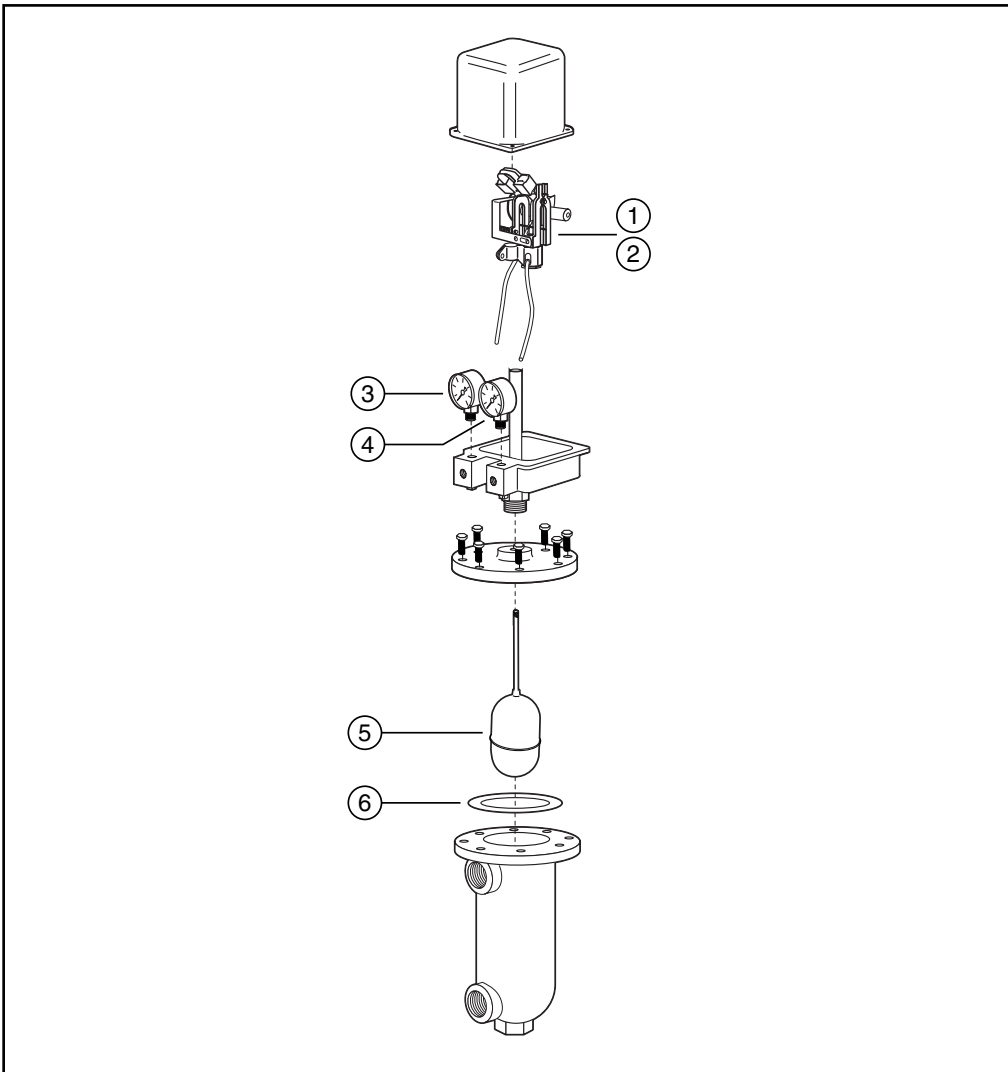

LIQUID LEVEL CONTROLS



Float Actuated

Series 27-W Liquid Level Controls



Components

Item Number	Part Number	Model Number	Description	Weight lbs. (kg)
1	334100	421-30	Float	1.5 (0.7)
2	311100	21-27	Gasket	0.1 (.05)
3	340100	SA27W-6	Valve assembly (includes item 2)	3.5 (1.6)

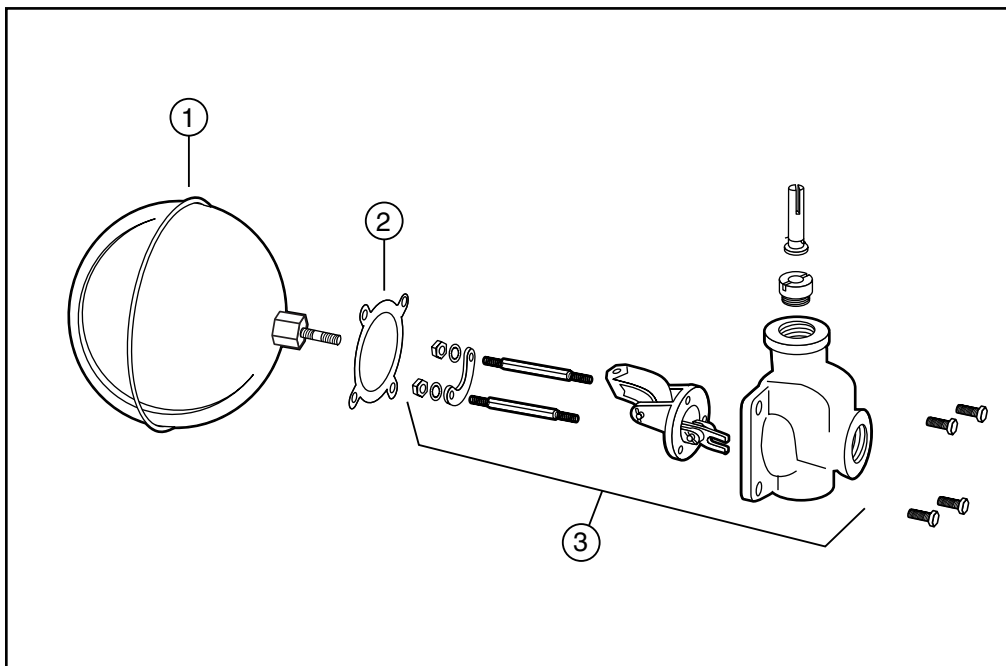



Float Actuated

Series 3155 Liquid Level Controls

Replacement Head Mechanisms

For Series	Repl. Head Model No.	Part Number	Description	Weight lbs. (kg)
3155	3155-HD	137800	Head mechanism	25.7 (11.7)



Components

Item Number	Part Number	Model Number	Description	Weight lbs. (kg)
1	310437	FLT-51-05	Float (includes item 2) (see note below)	2.5 (1.1)
2	304100	F-26	Gasket	0.1 (.05)
3	310443	BA-3155-05	Bellows bracket assembly (includes item 4) (see note below)	1.5 (0.7)
4	312800	37-27	Gasket	0.1 (.05)
5	333800	355-73	Gasket	4.0 (1.8)
6	333600	355-16	Gasket	0.1 (.05)
7	312900	37-28	Gasket	0.1 (.05)
8	353155	SA3155-6	Valve assembly	3.0 (1.4)

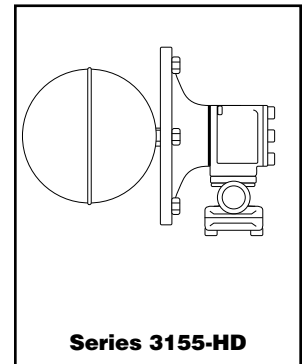

LIQUID LEVEL CONTROLS

NOTE:
One time float and bellows replacement is required when replacing bellows or float assemblies with date codes before February 2005 (05B).



Flow Switches – Liquid

Series FS4-3

General Purpose Liquid Flow Switches

Components

For Model	Item Number	Part Number	Model Number	Description	Weight lbs. (kg)
All models (except those below)					
	1	310451	FS4-15SS	Stainless steel paddle kit	0.1 (.05)
	2	305200	FS4-33	SPDT switch	0.3 (.14)
FS4-3RP	3	336101	FS4-15RP	Stainless steel paddle kit	0.8 (.36)
FS4-3F	4	336801	FS4-15F	Paddle kit	0.1 (.05)
FS4-3D	5	305512	FS4-3D-17	SPDT switch	0.3 (.14)
	6	304300	FS1-17	SPDT switch (next to adjustment screw)	0.3 (.14)



Series FS4-3

FLOW SWITCHES

Note: Paddle kits include screws and washers.

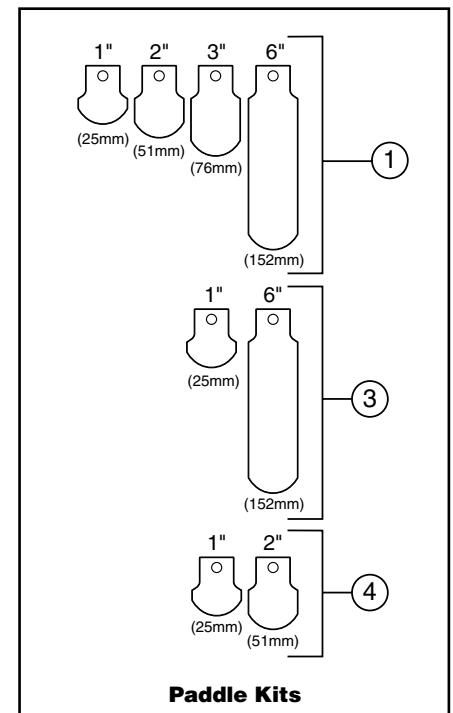
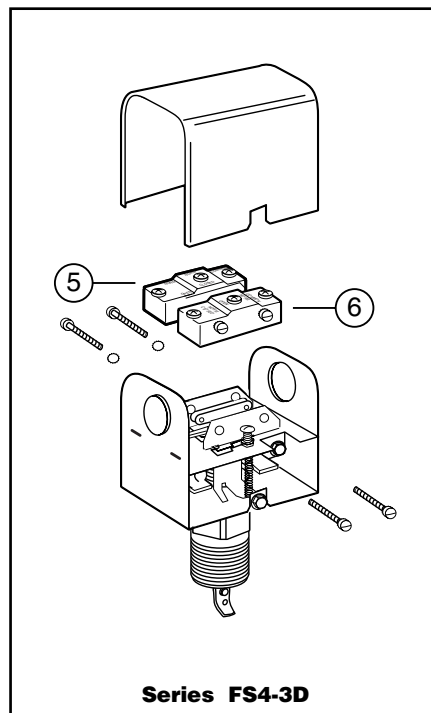
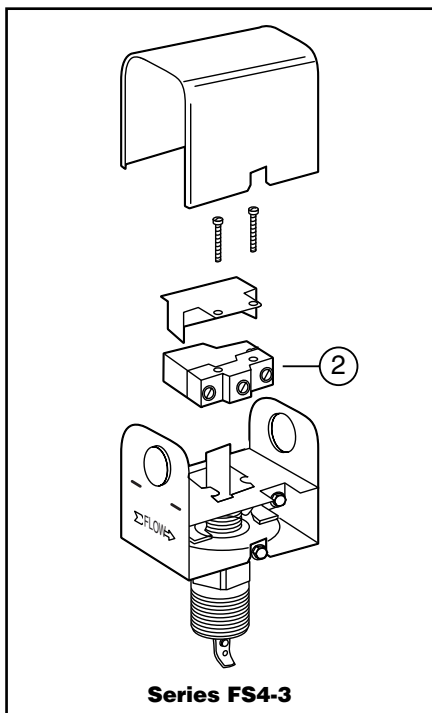



Flow Switches – Liquid

Series FS4-3T General Purpose Liquid Flow Switches

Components

Item Number	Part Number	Model Number	Description	Weight lbs. (kg)
1	305200	FS4-33	SPDT switch	0.3 (.14)
2	336900	FS4-3T-25	Paddle kit (includes O-ring)	0.1 (.05)



Series FS4-3T

Note: Paddle kits include screws and washers.

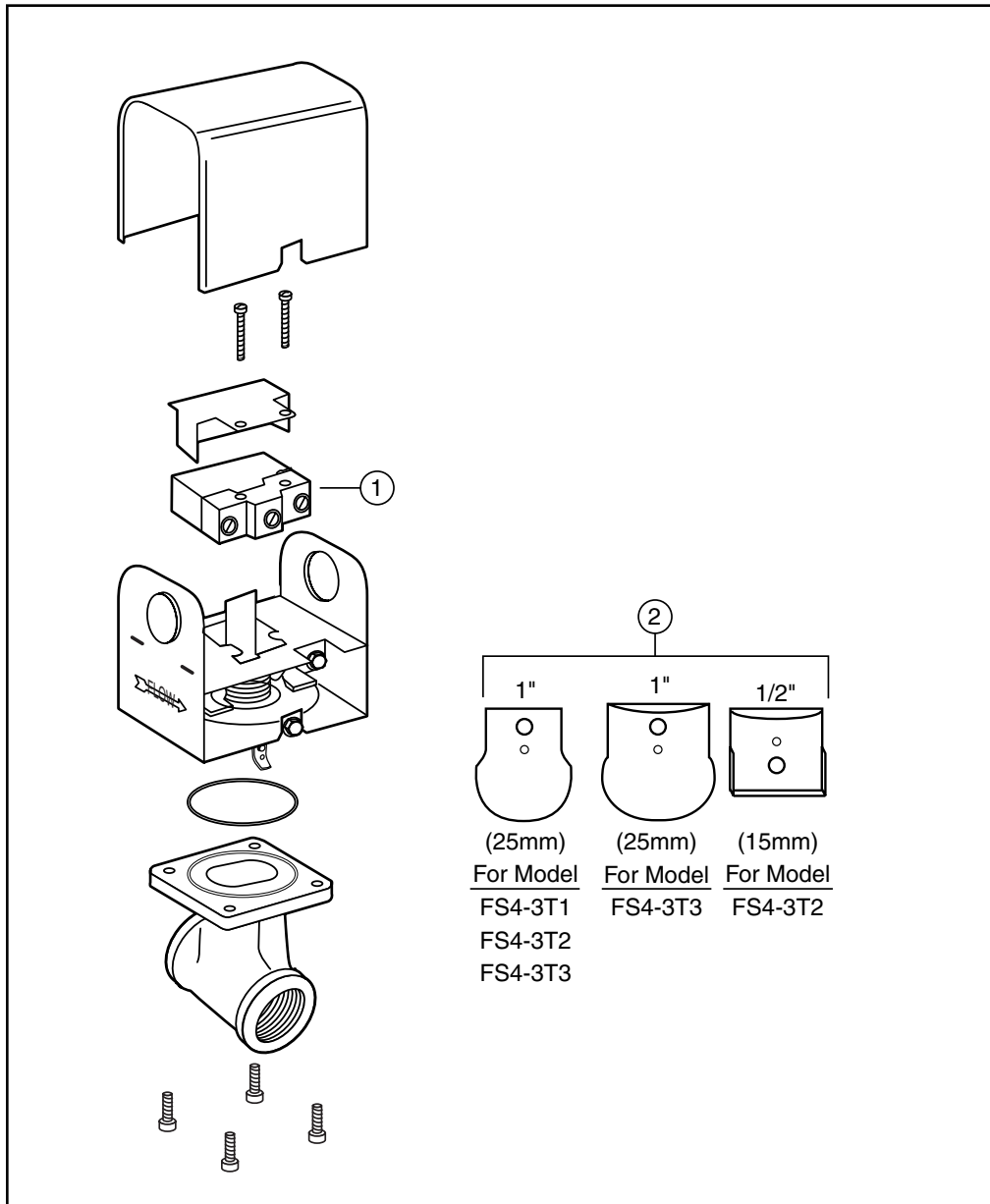

FLOW SWITCHES



Flow Switches – Liquid

Series FS5

General Purpose Liquid Flow Switches

Components

Item Number	Part Number	Model Number	Description	Weight lbs. (kg)
1	304300	FS1-17	Switch	0.3 (.14)

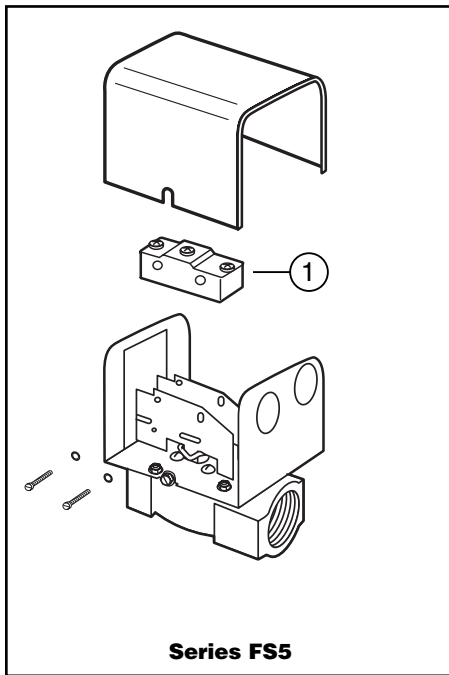

FLOW SWITCHES



Series FS8-W General Purpose Liquid Flow Switches

Components

Item Number	Part Number	Model Number	Description	Weight lbs. (kg)
1	307400	GSKT-FS8W	O-ring	0.1 (.05)
2	310478	FS8-33	Switch	0.3 (.14)
3	310451	FS4-15SS	Stainless steel paddle kit	0.1 (.05)
4	336101	FS4-15RP	Stainless steel paddle kit	.08 (0.4)



Series FS8-W

Note: Paddle kits include screws and washers.

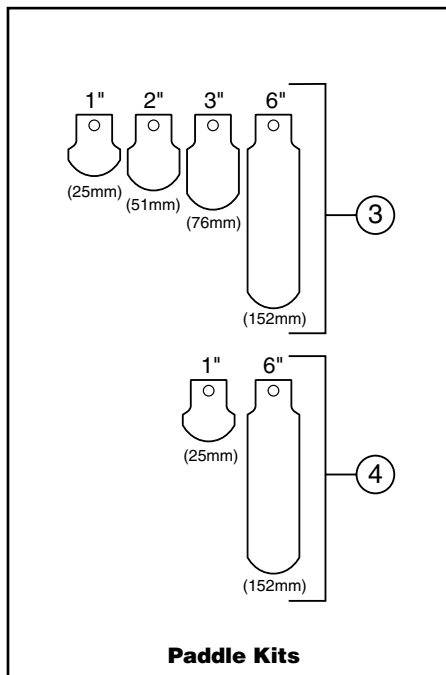
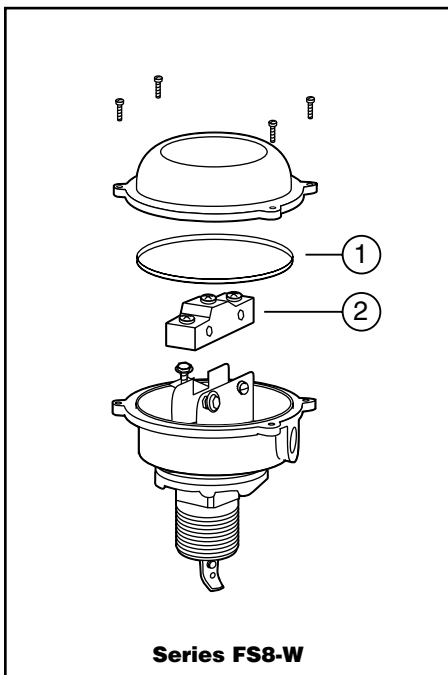

FLOW SWITCHES



Series FS250 General Purpose Liquid Flow Switches

Components

Item Number	Part Number	Model Number	Description	Weight lbs. (kg)
1	310801	GSKT-FS254	O-Ring	0.1 (.05)
2	310802	SW-FS250	Switch	0.3 (0.14)
3	310451	FS4-15SS	Stainless steel paddle kit	0.1 (.05)
4	336101	FS4-15RP	Stainless steel paddle kit	.08 (0.4)



FLOW SWITCHES

Note: Paddle kits include screws and washers.

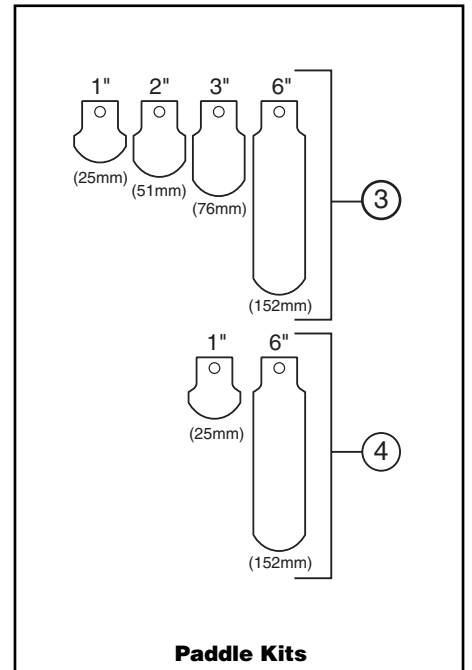
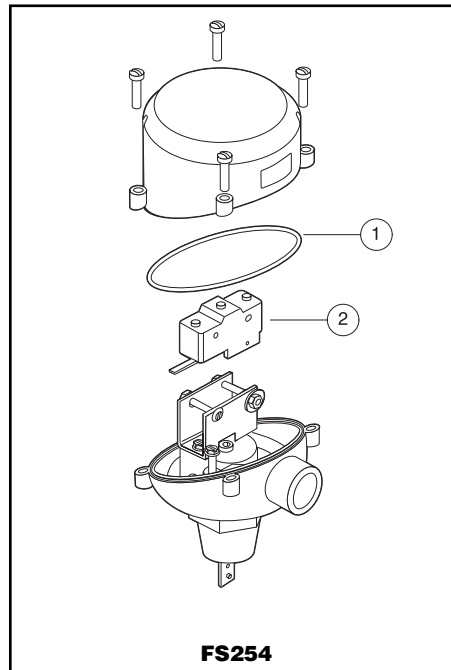
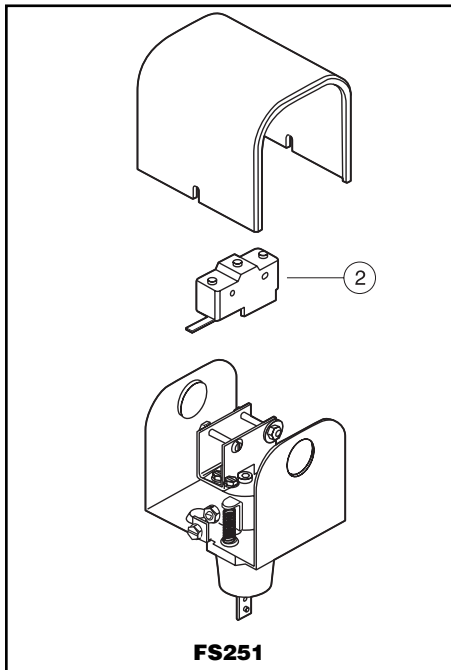



Flow Switches – Liquid

Series FS1 & FS1-W High Sensitivity Liquid Flow Switches

Components

Item Number	Part Number	Model Number	Description	Weight lbs. (kg)
1	300311	GSKT-FS1/6W	O-ring	0.1 (.05)
2	304300	FS1-17	Switch	0.3 (.14)

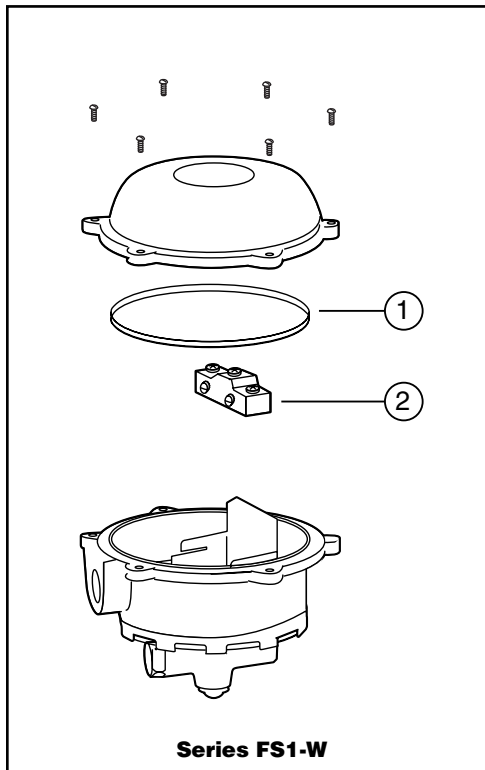
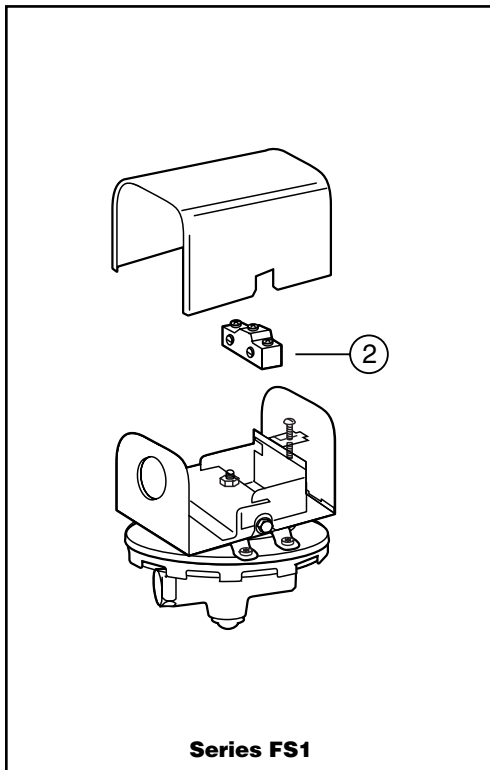

FLOW SWITCHES



Flow Switches – Liquid

Series FS6 & FS6-W High Sensitivity Liquid Flow Switches

Components

Item Number	Part Number	Model Number	Description	Weight lbs. (kg)
1	300311	GSKT-FS1/6W	O-ring	0.1 (.05)
2	304300	FS1-17	Switch	0.3 (.14)



FLOW SWITCHES

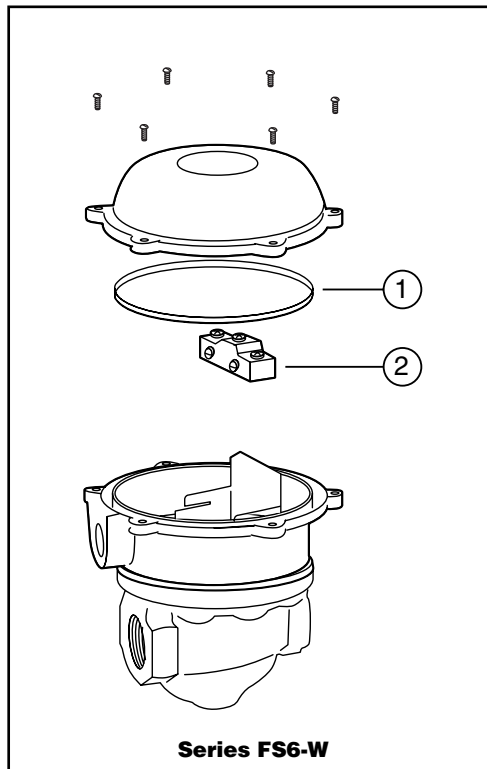
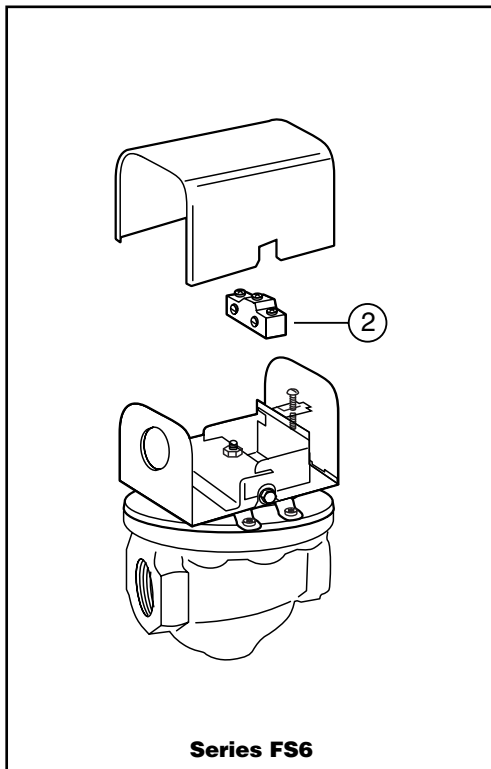



Flow Switches – Liquid

Series FS7-4, FS7-4L & FS7-4S Industrial Liquid Flow Switches

Components

For Series	Item Number	Part Number	Model Number	Description	Weight lbs. (kg)
FS7-4					
FS7-4S	1	307000	FS7-31	SPDT switch	0.3 (.14)
FS7-4L					
FS7-4					
FS7-4S	2	337550	FS7S-4R-4	Paddle arm	0.5 (.23)
FS7-4	3	306700	FS7-28	Bronze paddle kit	0.1 (.05)
FS7-4S	4	306800	FS7-28S	Stainless steel paddle kit	0.1 (.05)
FS7-4L	5*	337900	FS7-28L	Bronze paddle kit	0.1 (.05)
FS7-4L	6*	337650	FS7-VL-4R-4	Paddle arm	0.5 (.23)



Note: Paddle kits include screws and washers.

* Available on L models only.

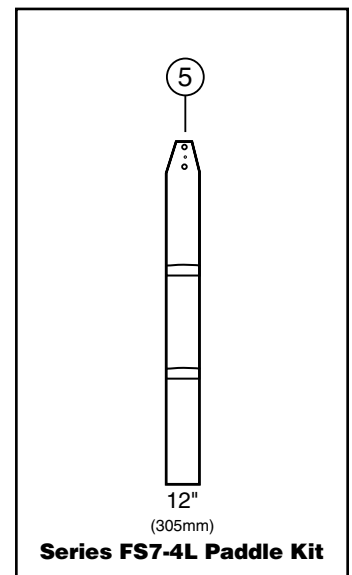
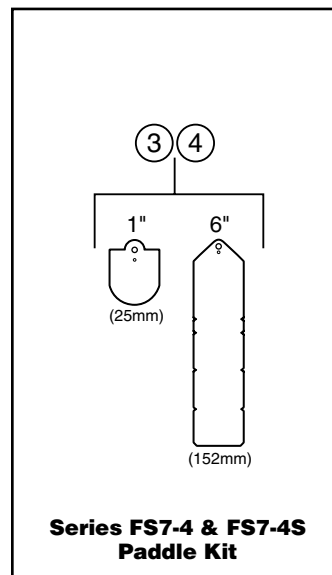
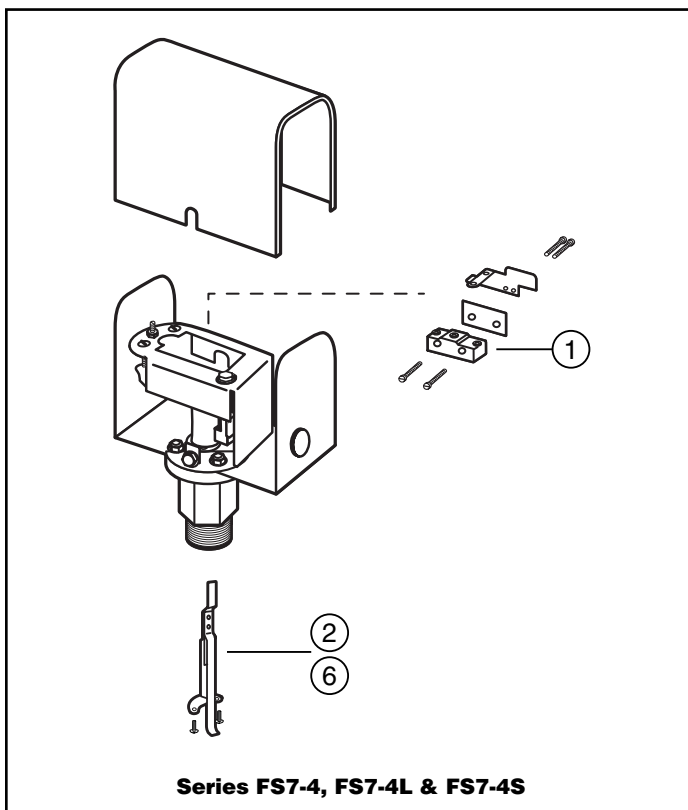



Flow Switches – Liquid

Series FS7-4E & FS7-4W Industrial Liquid Flow Switches

Components

For Series	Item Number	Part Number	Model Number	Description	Weight lbs. (kg)
All models	1	307000	FS7-31	SPDT switch	0.3 (.14)
	2	337550	FS7S-4R-4	Paddle arm	0.4 (.18)
FS7-4E FS7-4W	3	306700	FS7-28	Bronze paddle kit	0.1 (.05)
FS7-4SE FS7-4SW	4	306800	FS7-28S	Stainless steel paddle kit	0.1 (.05)
FS7-4W FS7-4SW	5	307200	FS7-W-43	Gasket	0.1 (.05)



FLOW SWITCHES

Note: Paddle kits include screws and washers.

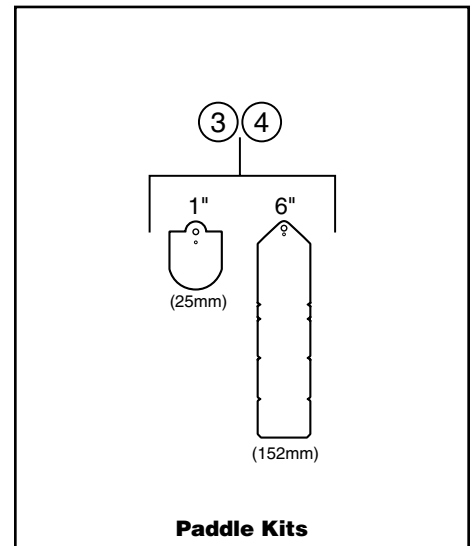
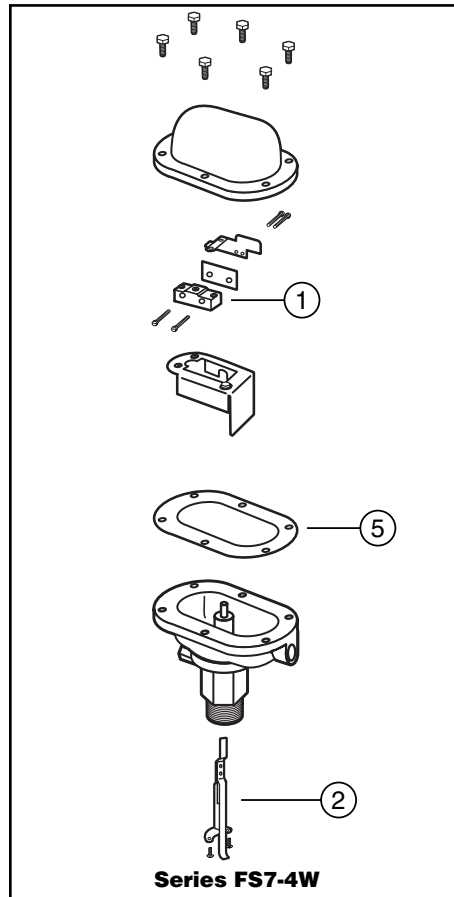
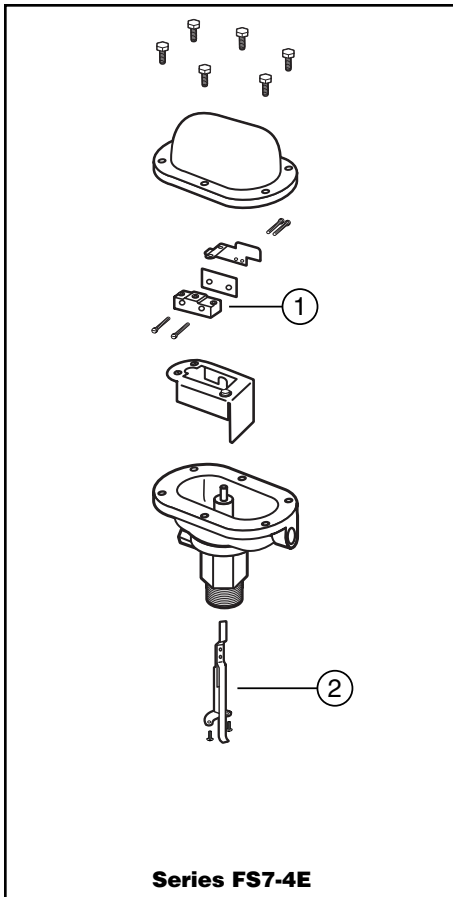



Flow Switches – Air

Series AF1 Air Flow Switches

Components

Item Number	Part Number	Model Number	Description	Weight lbs. (kg)
1	307000	FS7-31	SPDT switch	0.3 (.14)
2	301200	AF1-21	Gasket	0.1 (.05)
3	336000	AF1-122	Paddle kit for model AF1 & AF1-J (includes item 2)	0.1 (.05)
4	336050	AF1-S-122	Paddle kit for model AF1-S (includes item 2)	0.1 (.05)



Series AF1

Note: Paddle kits include screws and washers.

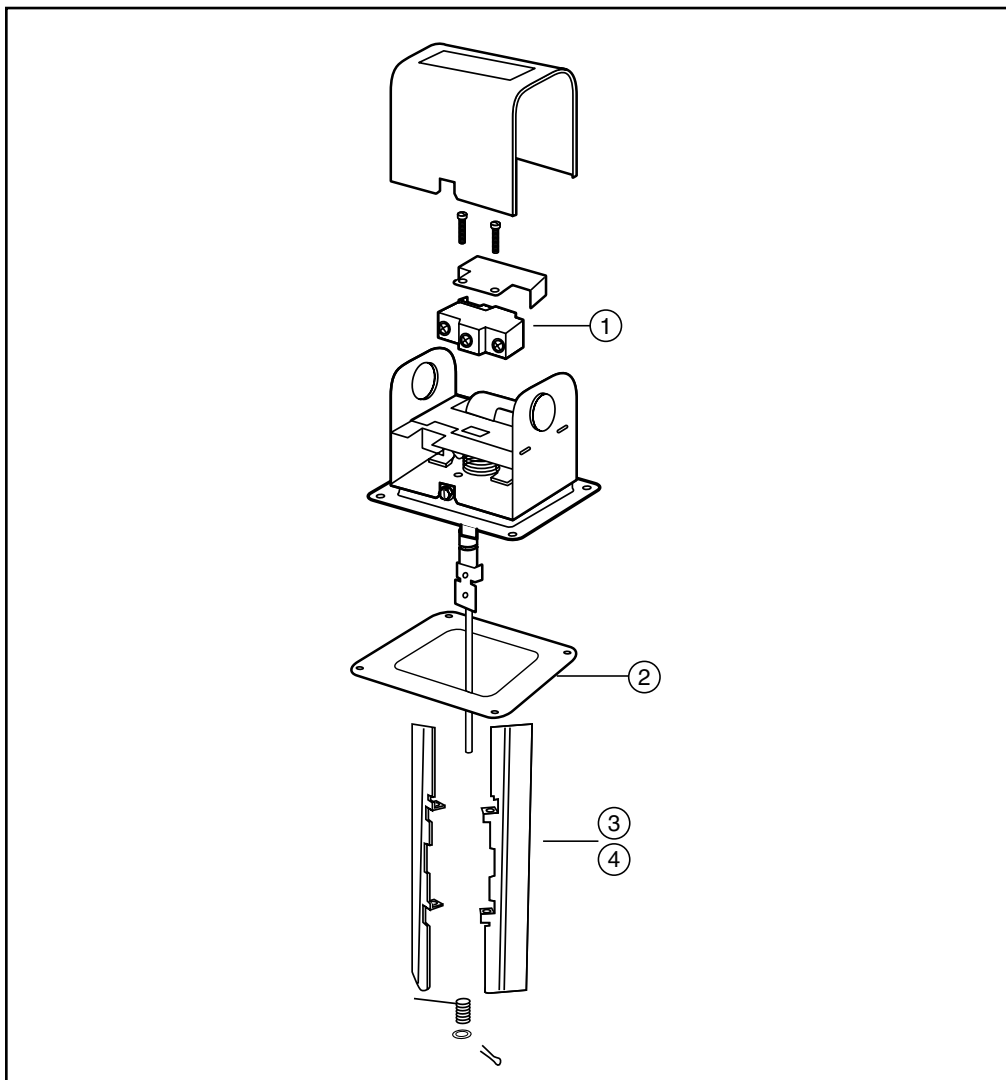

FLOW SWITCHES



Flow Switches – Air

Series AFE-1 Air Flow Switches

Components

Item Number	Part Number	Model Number	Description	Weight lbs. (kg)
1	304300	FS1-17	SPDT switch	0.3 (.14)
2	308300	AFE-1-122	Paddle kit (includes item 3)	0.1 (.05)
3	317352	AFE-1-21	Gasket	0.1 (.05)

Note: Paddle kits include screws and washers.

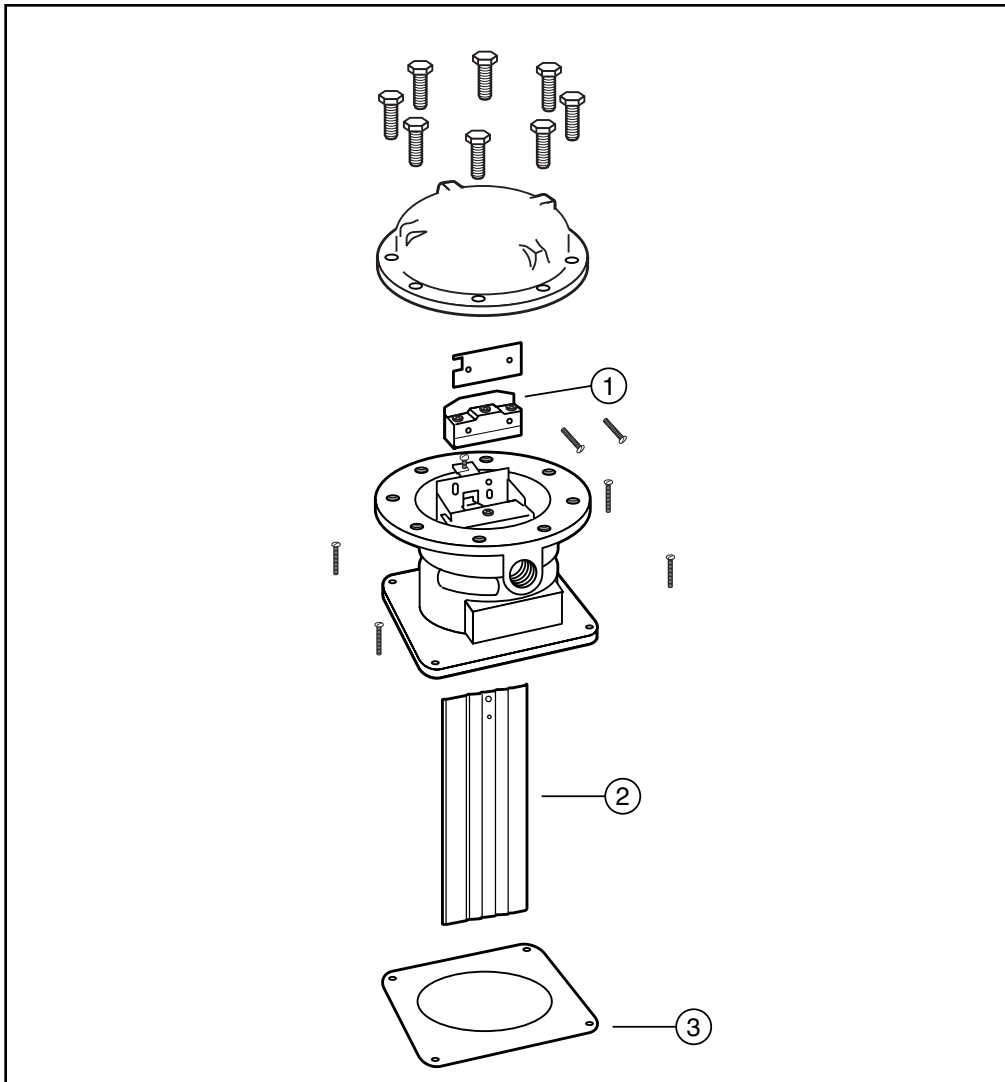



Flow Switches – Air

Series AF2 Air Flow Switches

Components

Item Number	Part Number	Model Number	Description	Weight lbs. (kg)
1	307000	FS7-31	SPDT switch	0.3 (.14)
2	301200	AF1-21	Gasket	0.1 (.05)
3	301400	AF2-122	Paddle kit (includes item 2)	0.1 (.05)



Note: Paddle kits include screws and washers.

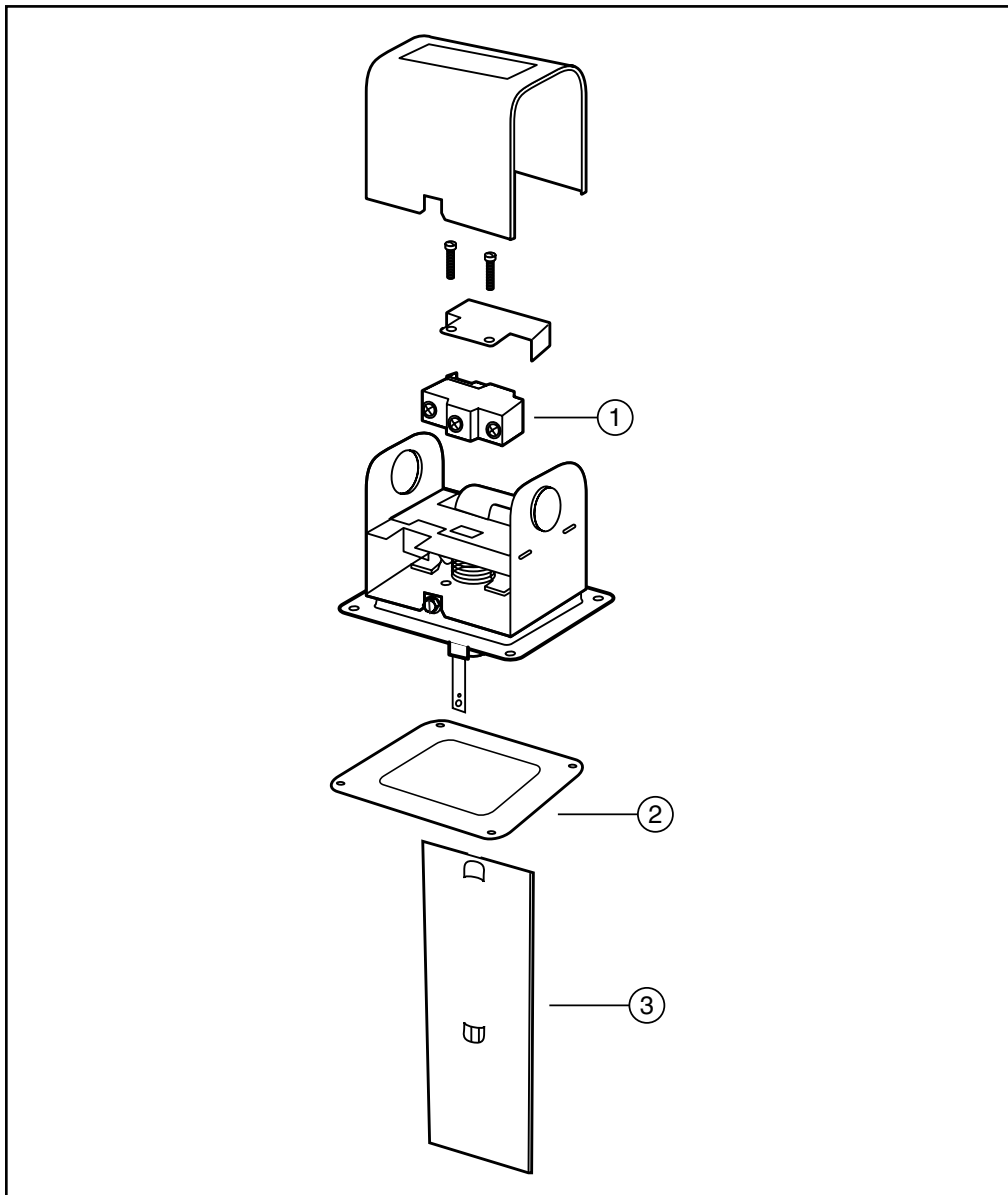

FLOW SWITCHES



Flow Switches – Air

Series AF3 Air Flow Switches

Components

Item Number	Part Number	Model Number	Description	Weight lbs. (kg)
1	307000	FS7-31	SPDT switch	0.3 (.14)
2	301200	AF1-21	Gasket	0.1 (.05)
3	301450	AF3-122	Paddle kit (includes item 2)	0.1 (.05)

Note: Paddle kits include screws and washers.



Series AF3

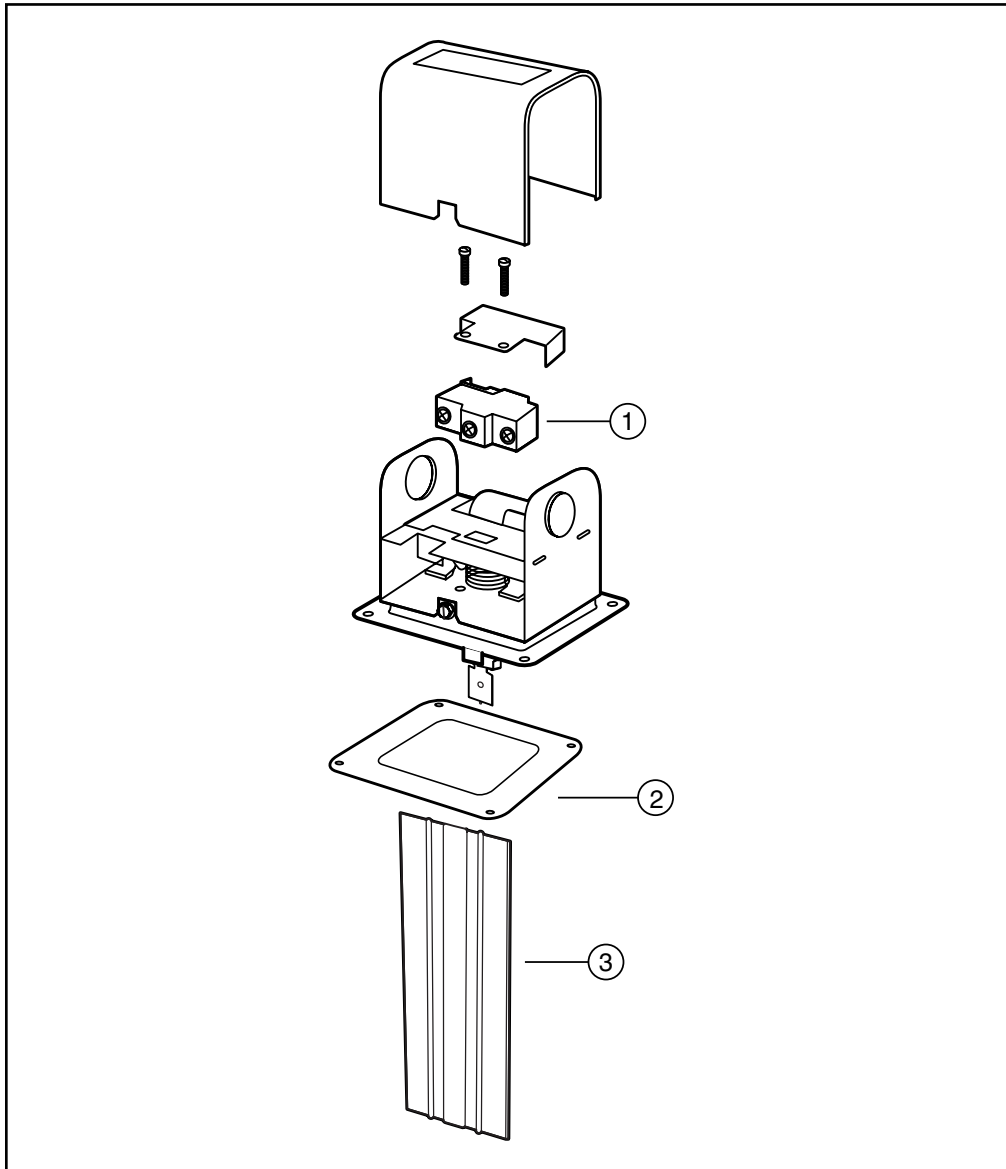



LEVEL & BOILER CONTROLS

Part Number	Catalog Number	Part Number	Catalog Number	Part Number	Catalog Number
110000	2	309000	7B-1R	335400	847-26
110100	2M	309100	11	335700	851-105
110300	5	309151	11M	335750	851S-105
110400	5M	309200	11MV	339500	SA21-6
110800	7B	310437	FLT-51-05	339700	SA21-38R
110900	7BM	310438	FLT-53-05	339800	SA25-5
127100	25A HD	310439	BA-51-05	339900	SA25A-6
129500	42-HD	310441	BA-53-05	340000	SA25A-15
129502	42S-HD	310442	BA-551-05	340100	SA27W-6
134900	51-HD	310443	BA-3155-05	340400	SA27T-75
135100	51-2-HD	310447	14-B	340600	SA37-30
135300	51-2M-HD	310452	CTRD-51	340700	SA37-38
135800	51S-HD	310453	CTRD-101	341300	SA42-125
136200	51S-2-HD	310462	SWA150S	341500	SA47-4
136250	51S-2M-HD	310463	SWA150S-M	341600	SA47-101-102
136600	551S-HD	310464	SWA150S-MD	341700	SA47C-101-102
137000	53-HD	310468	SWA158S	341900	SA47-104
137250	53-2M-HD	310469	SWA158S-M	342100	SA51S-6
137300	53-2-HD	310470	SWA159	342200	SA51-9
137800	3155-HD	310471	SWA-PFC-D	342300	SA51-9R
140300	61-HD	310472	SWA-PFC-R	342500	SA51-101-102
142600	63-HD	310473	STR-WF2	342800	SA53-6
143200	63-M-HD	310478	FS8-33	343100	SA60-30
144251	64-M-HD	310490	150E-CU	343200	SA63-5
144400	64-HD	310491	150M-CU	343400	SA63-30
146900	65-HD	310492	150E-PF	343500	SA64-2
147000	65R-HD	310600	21-3	343600	SA64-30
147200	165-HD	310800	21-12	343800	SA65-25
147350	165R-HD	311100	21-27	344000	SA65-125
153825	6667	311200	21-30	344100	SA66-35
153850	6667-MV	311400	21-109	344200	SA67-2
158200	80-HD	311450	21-130	344300	SA69-104
162400	93-HD	311800	27-9	344800	SA91-30B
162402	93-HDLS	311900	27T-9	345000	SA91-30P
162600	93-M-HD	312100	27T-13	345150	SA7-30
163200	93-7B-HD	312400	27T-70	345700	SA91-60
163300	93-7BM-HD	312600	37-20	347100	SA101-38
165300	94-HD	312700	37-26	347600	SA150-11
165302	94-HDLS	312800	37-27	347900	SA150-106R
165500	94A	312850	37-27R	348100	SA150-124
165700	94A-7B	312900	37-28	348200	SA150M-124
165800	94AM	312950	37-28R	348300	SA150-125
165900	94M	313200	37-39	348900	SA150M-436
166000	94-M-HD	313600	37A-130	349400	SA159-17
166300	94-7B	315450	47-171	349500	SA159-24
166400	94-7B-HD	316200	51S-114	351800	SA259-24
166500	94-7B-M-HD	317350	TC-U	352250	SA356-4R
171640	150E-HD	317353	TC-L	352255	SA357-6R
171650	150E-M	317354	TC-V	352600	SA551S-101-102
173000	150-HD	317600	65-11	352800	SA847-4
173003	150S-HD	318800	67-12	352925	SA851S-4
173100	150-MD-HD	318826	69-113	353155	SA3155-6
173103	150S-MD-HD	318827	69-114	354081	PA-800
173200	150-M-HD	320100	68-12	354082	PA-RB-120
173203	150S-M-HD	320500	69-112	354083	PA-RB-120II
173300	150-M-MD-HD	323300	92-68	354106	EA-157-L
173302	150S-M-MD-HD	324100	101-24V-48	354107	EA-157-S
178000	157R158HD	324435	37-101	354140	PA-800-RX2
178001	157R158S-HD	325400	150-14	354141	PA-800-U
178600	158-HD	325500	150-14H	354310	GSKT-PFC
178602	158S-HD	326950	150-436	354320	FLT-PFC
178700	158-M-HD	327500	155-14	354361	SWA-VFS
178702	158S-M-HD	328300	MA159	354370	GSKT-RS-1
178900	159-HD	328500	159-24	354380	GSKT-VFS-1
178902	159S-HD	329000	165G-39	354401	EA-RS
302500	CO-11	332800	MA259	354410	GSKT-RS-2
302600	CO-12	333600	355-16	354411	G-PFC-S
302900	CO-106	333800	355-73	354412	G-PFC-O
304100	F-26	333850	355-73R	310480	FLT-51
308000	S-2	334100	421-30	310482	FLT-53
308050	SA2-7	334600	MA559		

PART NUMBER

**FLOW SWITCHES**

Part Number	Catalog Number	Part Number	Catalog Number	Part Number	Catalog Number
300311	FS1/6W-GS KT	306800	FS7-28S	336000	AF1-122
301200	AF1-21	307000	FS7-31	336050	AF1-S-122
301400	AF2-122	307200	FS7W-43	336100	E-2-PDL
301450	AF3-122	307400	FS8W-12	336101	FS4-15RP
304290	FS1-14	308300	AFE-1-122	336800	FS4-15
304300	FS1-17	301478	FS8-33	336801	FS4-15F
304400	FS4-3COV	310451	FS4-15SS	336900	FS4-3T-25
305200	FS4-33	310801	FS254-12	337550	FS7S-4R-4
305512	FS4-3D-17	310802	FS250-33	337650	FS7-VL-4R-4
306700	FS7-28	317352	AFE-1-21	337900	FS7-28L

LEVEL AND BOILER CONTROLS

Part Number	Catalog Number	Description	Where Used
110000	2	CUTOFF/ALARM SWITCH	47, 51, 53, 63
110100	2M	CUTOFF/ALARM SW W/MAN RESET	47, 51, 53, 63
110300	5	SWITCH 2 LEVELS	93, 193, 94, 194
110400	5M	SWITCH 2 LEVELS MAN RESET	93, 193, 94, 194
110800	7B	PROPORTIONING LWCO SWITCH	93, 193, 94, 194
309000	7B-1R	RESISTOR/SLIDE WIRE KIT	7B, 93, 193, 94, 194
110900	7BM	PROPORTIONING LWCO SWITCH	93, 193, 94, 194
309100	11	SWITCH REPLACEMENT	61, 64, 67, 69, 70
309151	11M	CONVERSION/REPLACEMENT KIT	11, 64, 67
309200	11MV	REPLACEMENT SWITCH	67G, 69MV
310447	14-B	BLOW DOWN BALL VALVE	47, 67, 70B
310600	21-3	REPLACEMENT BRACKET	21
310800	21-12	GASKET	21
311100	21-27	GASKET	21, 25A, 27
311200	21-30	REPLACEMENT FLOAT	21
311400	21-109	REPLACEMENT CONNECTOR	21
127100	25A HD	HEAD MECHANISM	25A
311800	27-9	FLOAT & NIPPLE REPLACEMENT	27W
311900	27T-9	REPLACEMENT NIPPLE	25A
312100	27T-13	GASKET	25A
312400	27T-70	REPLACEMENT STUD	25A
312600	37-20	REPLACEMENT COVER	847, 551, 51S, 851, 53B
312700	37-26	GASKET	47
312800	37-27	GASKET	47, 51, 53, 3155
312900	37-28	GASKET	53, 3155, 21, 25A, 51
313200	37-39	GASKET	47, 53, 67, 70
324435	37-101	TETRASEAL O-RING	21, 25A, 47, 51, 53, 101A
313600	37A-130	REPLACEMENT FLOAT	847, 851
129500	42-HD	HEAD MECHANISM	42, 42A
129502	42S-HD	HEAD MECHANISM	42S, 42S-A
315450	47-171	REPLACEMENT CAP	47, 247
135100	51-2-HD	HEAD MECHANISM	51-2
135300	51-2M-HD	HEAD MECHANISM	51-2M
134900	51-HD	HEAD MECHANISM	51
135800	51S-HD	HEAD MECHANISM	51S
136200	51S-2-HD	HEAD MECHANISM	51S-2
136250	51S-2M-HD	HEAD MECHANISM	51S-2M
316200	51S-114	SEAT	51S
137300	53-2-HD	HEAD MECHANISM	53-2
137250	53-2M-HD	HEAD MECHANISM	53-2M
137000	53-HD	HEAD MECHANISM	53
140300	61-HD	HEAD MECHANISM	61
142600	63-HD	HEAD MECHANISM	63
143200	63-M-HD	HEAD MECHANISM	63M
144400	64-HD	HEAD MECHANISM	64
144251	64-M-HD	HEAD MECHANISM	64M
317600	65-11	GASKET	65, 65R, 165, 165R
146900	65-HD	HEAD MECHANISM	65
147000	65R-HD	HEAD MECHANISM	65R
318800	67-12	GASKET	61, 64, 67, 70, 80
320100	68-12	GASKET	70
320500	69-112	GASKET	69
318826	69-113	O-RING	69
318827	69-114	O-RING	69
158200	80-HD	HEAD MECHANISM	80, E-8
323300	92-68	GASKET	94, 194
162400	93-HD	HEAD MECHANISM	93, 193
162402	93-HDLS	HEAD MECHANISM LESS SWITCH	93, 193
162600	93-M-HD	HEAD MECHANISM	93M, 193M
163200	93-7B-HD	HEAD MECHANISM	93-7B, 193-7B
163300	93-7B-M-HD	HEAD MECHANISM	93-7BM, 193-7BM
165300	94-HD	HEAD MECHANISM	94, 194
165302	94-HDLS	HEAD MECHANISM LESS SWITCH	94, 194
166000	94-M-HD	HEAD MECHANISM	94M, 194M
166400	94-7B-HD	HEAD MECHANISM	94-7B, 194-7B
166500	94-7B-M-HD	HEAD MECHANISM	94-7BM, 194-7BM
324100	101-24V-48	TRANSFORMER	101A-24
325400	150-14	GASKET	93, 193, 150 Series
325500	150-14H	GASKET	150 Series w/Raised Face
326950	150-436	JUNCTION BOX COVER	42, 150 Series
173000	150-HD	HEAD MECHANISM	150 Series 28, 30

Part Number	Catalog Number	Description	Where Used
171640	150E-HD	HEAD, AUTOMATIC RESET	150E
171650	150E-M	HEAD, MANUAL RESET	150E
310490	150E-CU	CONTROL UNIT, AUTOMATIC RESET	150E
310491	150M-CU	CONTROL UNIT, MANUAL RESET	150E
310492	150E-PF	FLANGE/PROBE ASSEMBLY	150E
173003	150S-HD	HEAD MECHANISM	150 Series
173200	150-M-HD	HEAD MECHANISM	150-M Series
173203	150S-M-HD	HEAD MECHANISM	150-M Series
173100	150-MD-HD	HEAD MECHANISM	150-MD Series
173103	150S-MD-HD	HEAD MECHANISM	150-MD Series
173300	150-M-MD-HD	HEAD MECHANISM	150-M-MD Series
173302	150S-M-MD-HD	HEAD MECHANISM	150-M-MD Series
327500	155-14	SEAT FOR 3155	3155
178600	158-HD	HEAD MECHANISM	158
178602	158S-HD	HEAD MECHANISM	158
178700	158-M-HD	HEAD MECHANISM	158M
178702	158S-M-HD	HEAD MECHANISM	158M
328500	159-24	QUICK HOOK-UP Y FITTING	42A, 47, 64A, 67
178900	159-HD	HEAD MECHANISM	159
178902	159S-HD	HEAD MECHANISM	159
329000	165G-39	GASKET	165
147200	165-HD	HEAD MECHANISM	165
147350	165R-HD	HEAD MECHANISM	165R
333600	355-16	GASKET	3155
333800	355-73	GASKET	3155
334100	421-30	REPLACEMENT FLOAT	25A, 27
136600	551S-HD	HEAD MECHANISM	551S
335400	847-26	GASKET	21, 847, 851
335700	851-105	FLOAT ROD	851
335750	851S-105	FLOAT ROD	851S
137800	3155-HD	HEAD MECHANISM	3155
153825	6667	HEAD MECHANISM	67, 69
153850	6667-MV	HEAD MECHANISM	67G
302500	CO-11	GASKET	E-28, 63
302600	CO-12	GASKET	42, 61, 63, 64, 65, 42S
302900	CO-106	CAM	47, 51, 53, 63
310452	CTRD-51	CART/STRNR	51, 851
310453	CTRD-101	CART/STRNR	101A, 47, 247, 847
354106	EA-157-L	ELECTRODE LONG	157-RBP
354107	EA-157-S	ELECTRODE SHORT	157-RBP
304100	F-26	GASKET	221, 25A, 51, 53, 3155
310437	FLT-51-05	FLOAT	51, 3155
310438	FLT-53-05	FLOAT	53
354320	FLT-PFC	FLOAT	VFC, VFS, PFC
354412	G-PFC-O	OUTPUT GAUGE	PFC
354411	G-PFC-S	SUPPLY GAUGE	PFC
354310	GSKT-PFC	COVER GASKET	VFC, VFS, PFC
354370	GSKT-RS-1	COVER GASKET	RS1-BR1
354410	GSKT-RS-2	COVER GASKET	RS2-BR1
354380	GSKT-VFS-1	COVER GASKET	VFC, VFS
328300	MA159	QUICK HOOK-UP FITTINGS	42A, 47, 64A, 42S-A
332800	MA259	QUICK HOOK-UP FITTINGS	42A, 47, 64A
334600	MA559	QUICK HOOK-UP FITTINGS	67
354081	PA-800	PROBE STANDARD	PS 800, 850 Series w/Remote Probe
354140	PA-800-RX2	PROBE REMOTE	PS 800, 850 Series
354141	PA-800-U	PROBE LONG BARREL	PS 800, 850 Series w/Extended Probe
354082	PA-RB-120	PROBE SHORT	RB-120, PS 851/852
354083	PA-RB-122	PROBE RB-122	SP Series RB-122
308000	S-2	SWITCH COVER REPL	11, 61, 64, 67, 69, 70, 80
308050	SA2-7	SWITCH COVER REPLACEMENT	2, 47, 51, 53, 63
345150	SA7-30	TERMINAL PANEL FOR 7B	7B, 93, 193, 94, 194
339500	SA21-6	VALVE ASSEMBLY	21
339700	SA21-38R	STRAINER ASSEMBLY	21

Part Number	Catalog Number	Description	Where Used
339800	SA25-5	ARM ASSEMBLY	25A
339900	SA25A-6	VALVE SUBASSEMBLY	25A
340000	SA25A-15	STEM & DISC ASSEMBLY	25A
340400	SA27T-75	DIAPHRAGM SEAL ASSEM.	25A
340100	SA27W-6	VALVE MECHANISM ASSEM.	27W1
340600	SA37-30	FLOAT ASSEMBLY	47
340700	SA37-38	STRAINER BASKET ASSEM	51S, 53
341300	SA42-125	TWO WIRE PUMP SWITCH	42
341500	SA47-4	LARGE BELLOWS ASSEMBLY	47
341900	SA47-104	BELLOWS ASSEMBLY	247
341600	SA47-101-102	VALVE & STRAINER	47, 247, 847
341700	SA47C-101-102	VALVE & STRAINER	47C
342500	SA51-101-102	VALVE & STRAINER	51, 851
342200	SA51-9	STRAINER ASSEMBLY	51
342300	SA51-9R	STRAINER ASSEMBLY	25A
342100	SA51S-6	VALVE ASSEMBLY	51S
342800	SA53-6	VALVE ASSEMBLY	53
343100	SA60-30	FLOAT ASSEMBLY	65
343200	SA63-5	BELLOWS ASSEMBLY	63
343400	SA63-30	FLOAT ASSEMBLY	63
343500	SA64-2	BELLOWS BASE ASSEMBLY	64
343600	SA64-30	FLOAT ASSEMBLY	64
343800	SA65-25	SWITCH-DA	65
344000	SA65-125	SWITCH-RA	65R
344100	SA66-35	TUBE ASSEMBLY	67
344200	SA67-2	FLOAT & BELLOWS ASSEM.	61, 67, 69, 70
344300	SA69-104	REPLACEMENT SHIELD	69 Series
344800	SA91-30B	BURNER SWITCH	5, 6, 93, 193, 94, 194
345000	SA91-30P	PUMP SWITCH	5, 93, 193, 94, 194
345700	SA91-60	FLOAT	93, 193, 94, 194
347100	SA101-38	STRAINER BASKET ASSEM	47, 51, 101
347600	SA150-11	FLOAT & ROD	150 Series
347900	SA150-106R	BELLOWS ASSEMBLY	42, 42S, 150 Series
348100	SA150-124	3 WIRE SWITCH	42, 150 Series (Non "S")
348300	SA150-125	2 WIRE SWITCH	42, 150 Series (Non "S")
348200	SA150M-124	3 WIRE SWITCH	150 Series (Non "S")
310462	SWA150S	SNAP SWITCH ASSM.	150S
310463	SWA150S-M	SNAP SWITCH ASSM.	150S-M, 150S-M-MD
310464	SWA150S-MD	SNAP SWITCH ASSM.	150S-MD
310468	SWA158S	SNAP SWITCH ASSM.	158S
310469	SWA158S-M	SNAP SWITCH ASSM.	158S-M
310470	SWA159	SNAP SWITCH ASSM.	159
348900	SA150M-436	JUNCTION BOX COVER	150 Series
349400	SA159-17	BLACK Y ASSEMBLY	42A, 47, 64A, 42S-A
349500	SA159-24	LOWER QUICK HOOK-UP	42A, 47, 64A, 67, 42S-A
351800	SA259-24	UPPER QUICK HOOK-UP	47, 42A, 42S-A
352600	SA551S-101-102	VALVE/STR ASM	551S
352800	SA847-4	BELLOWS ASSEMBLY	847
352925	SA851S-4	BELLOWS ASSEMBLY	851, 851S
310443	BA-3155-05	BELLOWS ASSEMBLY	3155
310439	BA-51-05	BELLOWS BRACKET ASSEMBLY	51, 51S
310441	BA-53-05	BELLOWS BRACKET ASSEMBLY	53
353155	SA3155-6	VALVE ASSEMBLY	3155
310473	STR-WF2	STRAINER & ORIFICE KIT	WF-2 FEEDERS
310443	BA-3155-05	BELLOWS ASSEMBLY	3155
310471	SWA-PFC-D	VALVE ASSEMBLY-DA	PFC-1-G
310472	SWA-PFC-R	VALVE ASSEMBLY-RA	PFC-1-GR
354361	SWA-VFS	SWITCH MODULE	VFS
317353	TC-L	REPLACEMENT LOWER VALVE	TC-4
317350	TC-U	REPLACEMENT UPPER VALVE	TC-4
317354	TC-V	VACUUM BRKR & GASKET	TC-4

FLOW SWITCHES

Part Number	Catalog Number	Description	Where Used
336000	AF1-122	PADDLE KIT	AF1
301200	AF1-21	GASKET	AF-1, 2, 3
336050	AF1-S-122	PADDLE KIT	AF1-S
301400	AF2-122	PADDLE KIT	AF-2
301450	AF3-122	PADDLE KIT	AF-3, AFE-1
308300	AFE-1-122	PADDLE KIT	AFE-1
317352	AFE-1-21	GASKET	AFE-1
304290	FS1-14	GASKET	FS1, FS6
304300	FS1-17	REPLACEMENT SWITCH	FS1,4-3D,5,6,AFE-1
300311	FS1/6W-GSKT	O-RING SQUARE CUT	FS1-W, FS6-W
336801	FS4-15F	PADDLE KIT	FS4-3F
336101	FS4-15RP	PADDLE KIT	FS4-3RP, FS8-W, FS250
305200	FS4-33	REPLACEMENT SWITCH	All FS4-3's (Except D's
304400	FS4-3COV	COVER	FS4-3, AF-1,2 & 3
305512	FS4-3D-17	SWITCH	FS4-3D's
336900	FS4-3T-25	PADDLE KIT	FS4-3T's
306700	FS7-28	PADDLE KIT	FS7-4
306800	FS7-28S	PADDLE KIT	FS7-4S
337900	FS7-28L	REPLACEMENT PADDLE	FS7-4L
307000	FS7-31	REPLACEMENT SNAP SWITCH	FS7-4,AF-1,2&3,VFS
337650	FS7-VL-4R-4	LONG PADDLE ARM	FS7-4L
337550	FS7S-4R-4	PADDLE ARM KIT	FS7-4 & 4S
307200	FS7W-43	GASKET	FS7-4W
307400	FS8W-12	O-RING	FS8-W
310478	FS8-33	REPLACEMENT SWITCH	FS8-W
310451	FS4-15SS	PADDLE KIT	FS8-W, FS250
310801	FS254-12	GASKET	FS250
310802	FS250-33	SWITCH	FS250

Warranty Policy

ITT McDonnell & Miller warrants for a period of two (2) years from the date of manufacture or one (1) year from date of installation, whichever comes first, that all ITT McDonnell & Miller and all Hoffman Specialty products furnished by it are free from defects in materials and workmanship.

ITT McDonnell & Miller's liability for any breach of this Warranty shall be limited solely to replacement or repair at the sole option of ITT McDonnell & Miller, of any part or parts found to be defective during the Warranty Period providing the Product is properly installed and is being used for its intended purpose. Buyer must notify ITT McDonnell & Miller of any breach of this warranty, within the aforementioned Warranty Period by notifying the ITT McDonnell & Miller representative with responsibility for servicing the Buyer's account. Further, product alleged to be defective must be shipped by buyer to ITT McDonnell & Miller's representative, transportation charges prepaid.

It is expressly agreed that this shall be the sole and exclusive remedy of the buyer, under no circumstances shall ITT McDonnell & Miller be liable for any costs, loss, expense, damages, special damages, incidental damages or consequential damages arising directly or indirectly from the design, manufacture, sale, or use or repair of the product whether based upon warranty, contract, negligence or strict liability. In no event will liability exceed the purchase price of the product.

The warranty and limits of liability contained herein are in lieu of all other warranties and liabilities expressed or implied. All implied warranties or merchantability and fitness for a particular purpose are hereby disclaimed by ITT McDonnell & Miller and excluded from the warranty.

ITT McDonnell & Miller neither assumes nor authorizes any person to assume for it, any other Warranty obligation in connection with the sale of the Product. This Warranty shall not apply to any product or parts of products which (a) have been repaired or altered outside of authorized ITT McDonnell & Miller facilities; (b) have been subject to misuse, negligence or accident; or (c) have been used in a manner contrary to ITT McDonnell & Miller instructions.

In the case of Products not manufactured by ITT McDonnell & Miller, there is no warranty from ITT McDonnell & Miller, but ITT McDonnell & Miller will extend to the buyer any Warranty from ITT McDonnell & Miller's supplier of such products

Warranty Procedure

Return product to place of purchase or contact our local Manufacturer's Representative.

Return Goods Policy

Unused material may be returned for credit only with the written or oral consent of ITT McDonnell & Miller. This consent is in the form of an RGA number issued by ITT McDonnell & Miller, and is subject to the following conditions.

1. Materials must be unused, of current design, and in original cartons.
2. Credit will be issued based upon either a referenced invoice or product date code if an invoice is not referenced. Requestor is to supply copy of the referenced invoice if requested.
3. A 25% restocking charge will apply.
4. Unauthorized material returned to ITT McDonnell & Miller will be either refused or sent back to the sender freight collect by a carrier chosen by ITT McDonnell & Miller.
5. If material is received but subsequently found not to have met the above conditions, it will be sent back to the sender freight collect by a carrier chosen by ITT McDonnell & Miller.
6. Products which are obsolete or made to special order are not returnable.



IMPORTANT

- Product repairs made with non-McDonnell & Miller parts will invalidate our warranty as well as any agency recognitions. Without this recognition the product would no longer be eligible for use in listed end-use equipment.
- Previously used controls should never be installed on a new system. Always install new controls on a new boiler or system.
- A more frequent replacement interval may be necessary based on the condition of the unit at time of inspection. ITT McDonnell & Miller's warranty is one (1) year from date of installation or two (2) years from the date of manufacture.
- Use of water treatment can diminish product life. In such cases, components should be replaced on a more frequent basis.
- Visually inspect the inside of the float chamber during the annual inspection. Partial disassembly may be required.

Inspect all controls annually, and replace, repair or clean, as needed. All chambered units are to be blown down per manufacturers instructions and local code requirements. These requirements are to be determined by the local service company, and are based on water quality and system operation variables.

Refer to the installation instructions provided with the product for specific assembly and test procedures.
McDonnell & Miller products must also be maintained in accordance with the following ASME Code.

ASME Boiler and Pressure Vessel Code – Section VI Paragraph 7.07 G

Low-Water Fuel Cut-Off and Water Feeder Maintenance. Low-water fuel cut-offs and water feeders should be dismantled annually, by qualified personnel, to the extent necessary to insure freedom from obstructions and proper functioning of the working parts., Inspect connecting lines to boiler for accumulation of mud, scale, etc., and clean as required. Examine all visible wiring for brittle or worn insulation and make sure electrical contacts are clean and that they function properly. Give special atten-

tion to solder joints on bellows and float when this type of control is used. Check float for evidence of collapse and check mercury bulb (where applicable) for mercury separation or discoloration. Do not attempt to repair mechanisms in the field. Complete replacement mechanisms, including necessary gaskets and installation instructions are available from the manufacturer. After reassembly, test as per 7.05H.

ITT McDonnell & Miller controls manufactured after 1972 feature a stamped date code, so you can easily check the life expectancy and recommended replacement intervals. **If a control has no date stamp or does not have the ITT logo on it – replace it!**

See the chart (next page) for more specific information on maintenance and replacement intervals. Below are guides to help you quickly locate and translate the date code on McDonnell & Miller controls.

WHERE TO FIND



McDonnell & Miller

DATE CODES

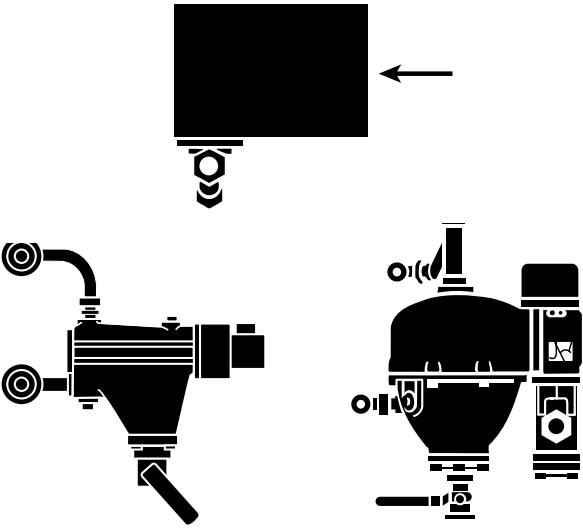



McDonnell & Miller

Product Date Code Translation

Month	Year	Example
A = January	W = 1979	K09 Translates to October 1990
B = February	X = 1980	
C = March	Y = 1981	
	Z = 1982	
D = April	38 = 1983	
	48 = 1984	
E = May	58 = 1985	
	68 = 1986	
F = June	78 = 1987	
	88 = 1988	
G = July	98 = 1989	
	19 = 1991	
H = August	29 = 1992	
J = September	39 = 1993	
	49 = 1994	
K = October	59 = 1995	
	96 = 1996	Beginning 1996 the year is no longer reversed. 96K Translates to October 1996
L = November	97 = 1997	
	98 = 1998	
	99 = 1999	
M = December	00 = 2000	
	01 = 2001	
	02 = 2002	
	03 = 2003	
	04 = 2004	
	05 = 2005	
	06 = 2006	
	07 = 2007	
	08 = 2008	
	09 = 2009	

Recommended Replacement Intervals

Product	Series	Recommended Maintenance	Recommended Replacement Interval (Maximum)
Low Water Cut-Offs	150, 157, 158, 159, 150S, 157S, 158S, 159S	Blow down and test daily inspect annually.	15 years
	69, 169, 269, 369, 469	Inspect and test annually.	10 years
	67, 767 70, 70-B	Blow down weekly. Inspect and test annually.	10 years
	61, 63, 64, 764	Blow down weekly. Inspect and test annually.	10 years
	42	Blow down daily. Inspect and test annually.	10 years
	93, 94, 193, 194	Blow down and test daily. Inspect and test annually.	15 years
	750, PS-800, PA-850, 900, RB-120	Inspect and test annually.	15 years
	RB-24	Inspect and test annually.	10 years
Water Feeders	WF2/Uni-Match®	Inspect and test annually. Replace filter annually.	10 years
	101-A	Inspect, test, and replace cartridge valve annually.	10 years
	21, 221, 25-A, 53, 551-S, 847, 3155	Inspect and test annually.	15 years
	47, 51, 53, 247	Blow down weekly. Inspect and replace cartridge valve annually.	10 years
Liquid Level Controls	LPC-2000, PS-850, PCH PCL, PFC, VFC, VFS	Inspect and test annually.	15 years
	18, 18-SS, 27-W	Inspect and test annually.	5 years
Replacement Blow Down Valves	14-B	Inspect and test annually.	10 years
	14	Replace with 14-B blow down valve.	3 years
Replacement Probes	750, PS-800, PS-850, 900, RB-120, PCH, PCL	Inspect annually.	10 years
Replacement Head Mechanisms for Commercial/Industrial Applications	25-A, 42, 51, 51-S, 53, 61, 63, 64, 67, 70, 93 94, 150, 150S, 157, 157S, 193, 194	Inspect and test annually.	5 years



ITT

McDONNELL & MILLER

Stocked ... Sold ... Serviced EVERYWHERE!

FOR MORE DETAILS CALL YOUR LOCAL McDONNELL & MILLER REPRESENTATIVE

ALABAMA

James M. Pleasants Co., Inc.
Irontdale (Birmingham)
Phone: 205/956-2362

ALASKA

Columbia Hydronics Co.
Anchorage
Phone: 907/563-3327

ARIZONA

J & B Sales Company
Phoenix
Phone: 602/258-1545

ARKANSAS

Johnson & Scott, Inc.
Little Rock
Phone: 501/803-9520
Hydronic Technology Inc.
Shreveport, LA
Phone: 318/797-1500
Boone & Boone Sales Co., Inc.
Tulsa, OK
Phone: 918/664-9756

CALIFORNIA

California Hydronics Corp.
Hayward (San Francisco)
Phone: 510/293-1993
Rocklin (Sacramento)
Phone: 510/293-1993
San Jose
Phone: 408/295-5874
Dawson Co.
Altadena (Los Angeles)
Phone: 626/797-9710
San Diego
Phone: 858/541-7867

COLORADO

McNevin Company
Aurora (Denver)
Phone: 303/322-0165

CONNECTICUT

F.I.A., Inc.
Middleton
Phone: 781-938-8900

DELAWARE

R. D. Bitzer Co., Inc.
Bensalem, PA
Phone: 215/604-6600
Cummins-Wagner Co., Inc.
Annapolis Junction, MD
Phone: 800/966-1277
301/490-9007

FLORIDA

George A. Israel Jr., Inc.
Jacksonville
Phone: 904/355-7867
Miami
Phone: 305/592-5343
Orlando
Phone: 407/423-5078
Tampa
Phone: 813/839-2161
79 Holly Circle
Tequesta, FL 33469
Phone: 561/248-3556
James M. Pleasants Co., Inc.
Panhandle
Phone: 205/956-2362

GEORGIA

James M. Pleasants Co., Inc.
Duluth
Phone: 678/507-1091
Norcross
Phone: 800/522-1861
678/507-1091
George A. Israel Jr., Inc.
Jacksonville, FL
Phone: 904/355-7867

HAWAII

CBC Inc.
Kailua
Phone: 808/263-8838

IDAHO

Gritton & Associates, Inc.
Salt Lake City, UT
Phone: 801/486-0767
Columbia Hydronics Co.
Boise
Phone: 208/345-2744

ILLINOIS

Bornquist, Inc.
Chicago
Phone: 773/774-2800
Blackmore & Glunt, Inc.
Maryland Hgts. (St. Louis) MO
Phone: 314/878-4313
Sandberg Co., Inc.
East Moline
Phone: 309/796-2371
Hydronic & Steam Equip. Co., Inc.
Indianapolis, IN
Phone: 800/669-4926

INDIANA

Hydronic & Steam Equip. Co., Inc.
Indianapolis
Phone: 800/669-4926
Evansville
Phone: 800/473-2753
Ft. Wayne
Phone: 260/489-5785
South Bend
Phone: 800/932-6490
Bornquist, Inc.
Chicago, IL
Phone: 773/774-2800
Blackmore & Glunt, Inc.
Cincinnati, OH
Phone: 513/489-5225

IOWA

Products, Inc.
Des Moines
Phone: 515/288-5738
Sandberg Co., Inc.
East Moline, IL
Phone: 309/796-2371
Verne Simmonds Co.
Omaha, NE
Phone: 402/592-3131

KANSAS

Blackmore & Glunt, Inc.
Lenexa (Kansas City)
Phone: 913/469-5715

KENTUCKY

Blackmore & Glunt, Inc.
Cincinnati, OH
Phone: 513/489-5225
Hydronic & Steam Equip. Co., Inc.
Evansville, IN
Phone: 800/473-2753
812/473-0330
Johnson & Scott, Inc.
Nashville, TN
Phone: 615/254-5454

LOUISIANA

Hydronic Technology Inc.
New Orleans
Phone: 800/365-6746
504/827-1163
Shreveport
Phone: 800/673-5737
318/797-1500

MAINE

F.I.A., Inc.
Woburn (Boston) MA
Phone: 781/938-8900

MARYLAND

Cummins-Wagner Co., Inc.
Annapolis Junction
Phone: 800/966-1277
301/490-9007
Thermoflo Equipment Co., Inc.
Pittsburgh, PA
Phone: 412/366-2012

MASSACHUSETTS

F.I.A., Inc.
Woburn (Boston)
Phone: 781/938-8900

MICHIGAN

R. L. Deppmann Co.
Southfield (Detroit)
Phone: 248/354-3710
Grand Rapids
Phone: 616/656-0821
Bridgeport
Phone: 989/652-3049
Hydro-Flo Products, Inc.
Brookfield (Milwaukee), WI
Phone: 262/781-2810

MINNESOTA

Mulcahy Company
Eagan
Phone: 651/686-8580

MISSISSIPPI

Hydronic Technology Inc.
New Orleans, LA
Phone: 800/365-6746
504/827-1163
Johnson & Scott, Inc.
Little Rock, AR
Phone: 501/803-9520

MISSOURI

Blackmore & Glunt, Inc.
Lenexa (Kansas City) KS
Phone: 913/469-5715
Maryland Hgts. (St. Louis)
Phone: 314/878-4313

MONTANA

Columbia Hydronics Co.
Spokane, WA
Phone: 509/242-1118

NEBRASKA

Verne Simmonds Co.
Omaha
Phone: 402/592-3131

NEVADA

California Hydronics Corp.
Reno, NV
Phone: 775/786-6068
Gritton & Associates, Inc.
Las Vegas, NV
Phone: 801/486-0767

NEW HAMPSHIRE

F.I.A., Inc.
Woburn (Boston) MA
Phone: 781/938-8900

NEW JERSEY

Wallace-Eannace Assoc., Inc.
Franklin Lakes
Phone: 201/891-9550
R. D. Bitzer Co., Inc.
Bensalem, PA
Phone: 215/604-6600

NEW MEXICO

Boyd Engineering Co., Inc.
Albuquerque
Phone: 505/275-1250

NEW YORK

Wallace-Eannace Assoc., Inc.
Plainview (NYC)
Phone: 516/454-9300
Frank P. Langley Co., Inc.
E. Rochester
Phone: 585/248-5010
Amherst (Buffalo)
Phone: 716/691-7575
Johnson City
Phone: 607/766-9950
Albany
Phone: 518/459-1060
Syracuse Thermal Products, Inc.
East Syracuse
Phone: 315/437-7321

NORTH CAROLINA

James M. Pleasants Co., Inc.
Greensboro
Phone: 800/365-9010
336/378-9911
Charlotte
Phone: 704/545-0145
Raleigh
Phone: 919/845-1960
Wilmington
Phone: 910/794-5447

NORTH DAKOTA

Mulcahy Company
Eagan, MN
Phone: 651/686-8580

OHIO

Blackmore & Glunt, Inc.
Cincinnati
Phone: 513/489-5225
R. L. Deppmann Co.
Richfield
Phone: 330/468-1102

OHIO (Cont'd.)

Steffens-Shultz, Inc.
Columbus
Phone: 614/274-5515
Dayton, Ohio
Phone: 937/454-4980

Thermoflo Equipment Co., Inc.
Pittsburgh, PA
Phone: 412/366-2012

OKLAHOMA

Boone & Boone Sales Co., Inc.
Oklahoma City
Phone: 405/525-7475
Tulsa
Phone: 918/664-9756

OREGON

Columbia Hydronics Co.
Vancouver, WA
Phone: 360/883-2600

PENNSYLVANIA

R. D. Bitzer Co., Inc.
Bensalem
Phone: 215/604-6600
Thermoflo Equipment Co., Inc.
Pittsburgh
Phone: 412/366-2012
Frank P. Langley Co., Inc.
Amherst (Buffalo) NY
Phone: 716/691-7575

RHODE ISLAND

F.I.A., Inc.
Woburn (Boston) MA
Phone: 781/938-8900

SOUTH CAROLINA

James M. Pleasants Co., Inc.
Greensboro, NC
Phone: 800/365-9010
336/378-9911
Columbia
Phone: 803/798-1405
Greenville
Phone: 864/232-0200

SOUTH DAKOTA

Mulcahy Company
Eagan, MN
Phone: 651/686-8580
Verne Simmonds Co.
Omaha, NE
Phone: 402/592-3131

TENNESSEE

Johnson & Scott, Inc.
Nashville
Phone: 615/254-5454
Cordova (Memphis)
Phone: 901/388-2919
James M. Pleasants Co., Inc.
Greensboro, NC
Phone: 800/365-9010
336/378-9911

Texas

Boyd Engineering Co., Inc.
Albuquerque, NM
Phone: 505/275-1250
Oslin Nation Co.
Dallas
Phone: 214/631-5650
Ft. Worth
Phone: 817/590-2500

TEXAS (Cont'd.)

Oslin Nation Co. (Cont'd)
Houston
Phone: 713/699-3500
San Antonio
Phone: 800/243-7756

UTAH

Gritton & Associates, Inc.
Salt Lake City
Phone: 801/486-0767

VERMONT

F.I.A., Inc.
Woburn (Boston) MA
Phone: 781/938-8900

VIRGINIA

TLA, Inc.
Richmond
Phone: 804/321-4444
Virginia Beach
Phone: 757/497-3567
Cummins-Wagner Co., Inc.
Annapolis Junction, MD
Phone: 800/966-1277
301/490-9007

WASHINGTON

Columbia Hydronics Co.
Tukwile
Phone: 206/241-0500
Spokane
Phone: 509/242-1118
Vancouver
Phone: 360/883-2600

WASHINGTON, DC

Cummins-Wagner Co., Inc.
Annapolis Junction, MD
Phone: 800/966-1277
301/490-9007

WEST VIRGINIA

Blackmore & Glunt, Inc.
Cincinnati, OH
Phone: 513/489-5225

TLA, Inc.

Richmond, VA
Phone: 804/321-4444
Thermoflo Equipment Co., Inc.
Pittsburgh, PA
Phone: 412/366-2012

WISCONSIN

Hydro-Flo Products, Inc.
Brookfield (Milwaukee)
Phone: 262/781-2810
Mulcahy Company
Eagan, MN
Phone: 651/686-8580

WYOMING

Gritton & Associates, Inc.
Salt Lake City, UT
Phone: 801/486-0767
J. E. McNevin Co.
Aurora (Denver), CO
Phone: 303/322-0165

INTERNATIONAL:
Visit our website or contact our office at the address shown below.

© COPYRIGHT 2008 BY
ITT CORPORATION
PRINTED IN U.S.A. 9-08

THE ITT ENGINEERED BLOCKS SYMBOL AND
ENGINEERED FOR LIFE ARE REGISTERED
TRADEMARKS OF ITT CORPORATION

ITT

8200 N. Austin Avenue
Morton Grove, IL 60053
Phone: (847) 966-3700
Fax: (847) 966-9052
<http://www.mcdonnellmiller.com>

